



FAÇADE
CREATIONS

Fire Rated Doors & Windows
Installation & Maintenance

FIRE-RATED DOORS AND TECHNICAL WINDOWS INSTALLATION GUIDE

Please read and follow this Installation Guide, which contains important information on the installation and maintenance of fire-rated doors and technical windows made of aluminium profiles. Correct installation and careful maintenance of the MB-78EI fire-rated doors and technical windows are essential for the service life and operational safety.

This document is intended for fire-rated doors and technical windows installers to enable proper integration of those products into the building structure, and therefore all the descriptions of installation operations, attached diagrams and drawings are limited only to activities that lie with the installer. It is assumed that fire-rated technical windows and doors are fully prefabricated in the production facility in accordance with ALUPROF MB-78EI technical documentation and delivered assembled, except in cases where, due to their size, the constructions cannot be road-transported or brought into the building.

In specific cases, please follow the system documentation – ALUPROF MB-78EI System Catalogue ‘Fire partitions with doors rated EW15, EI15, EW30, EI30, EI45, EW60, EI60, EI90’ – issue 11/2019 or more recent, or contact the Product manufacturer.

Introduction

Door shall mean a construction product consisting of a frame, one or more leaves, a threshold (or door without a threshold) attached to a building structure, that may include top light, side light, and elements such as hinges, locks and mechanisms, glass or other infills. A fire-rated technical window is a door-type construction product in which all elements of the frame, including the threshold, are made of the same profile.

Correct fabrication of doors or technical windows in the production facility and their subsequent careful installation in accordance with this guide, as well as their periodic maintenance are critical for the service life, operating parameters and safety. Correct installation of doors and technical windows is particularly important because when closed, the doors and windows complement the fire properties of the walls into which they are integrated and provide a protective barrier for people and property in the event of fire.

The effectiveness of fire protection is achieved not only through the specific design of doors and technical windows, but is also dependent on the degree of care with which the installation of the entire fire structure is carried out.

In order to provide sufficient assurance that fire doors and technical windows are installed correctly, it is recommended they are installed by qualified personnel with relevant expertise, who underwent training and practical examinations, because placing a label on the product and submitting a Declaration of Performance by the Manufacturer creates a legal responsibility for the installed product.

Installer's tasks

1. Delivery and on-site inspection

It is assumed that fire-rated doors and technical windows are manufactured in an industrial process and delivered to the construction site as fully finished frames and door leaves, equipped with appropriate fittings or with prepared mounting holes enabling the installation of fittings or other mechanisms, which have not been installed in the production facility due to the potential transport damage (handles, door knobs, door closers, panic bars). Only in the case of large-size doors with side/top light, frames can be delivered in elements, however, the door leaves must always be fully manufactured in the production facility.

1.1. Checking the delivery

Delivery of door and technical windows to the construction site also includes deliveries of glass, supplementary system materials (accessories, fittings, mechanisms, insulators, gaskets, etc.) and installation materials (dowels, anchors, sealing compounds, etc.).

The following delivery elements are also important: detailed technical plans for doors and windows, designs and guidelines on how and where to install them, technical specifications, Declaration of Performance for doors covered by harmonised product standards (external doors with CE marking) or European Technical Assessments (internal doors and walls with CE marking) or National Declaration of Performance for doors and walls covered by National Technical Assessments or ITB's Technical Approvals (products with B marking), and delivery documents that enable to check the completeness of a delivery. In addition, the following guides shall be provided:

- operational safety guide for doors,
- maintenance guide and cleaning guide.

The installer should:

- check whether the load is properly fastened down onto a means of transport before the unloading begins,
- check the completeness of the material delivery and required documentation,
- draw up an act of acceptance (in terms of quality and quantity),
- identify the product and its place of installation,
- secure the delivery, ensure its proper storage and on-site handling,
- make or assess whether the building aperture was properly prepared.

1.2. On-site storage of fire constructions and glass

If the fire partitions are not installed immediately after delivery, the following on-site storage rules must be observed:

- the constructions of fire-rated doors and technical windows, as well as other elements of delivery should be stored in their original packaging, aluminium profiles should be protected with a self-adhesive foil, which can only be removed after the installation is complete,
- unglazed door leaves and frames should be preferably stored in vertical position, leaning against stable walls or positioned on racks, with individual elements separated with spacers made of soft cardboard or other soft materials,
- aluminium constructions, seals and other installation materials should be stored in dry, ventilated rooms with positive temperature from 5°C to 30°C,
- stored products should not be directly exposed to heaters or other heat emitters or to high direct sunlight,
- fire-resistant glass must be stored on pallets or racks supplied with glass, the glass must be evenly distributed on both sides of the pallet or racks delivered with glass, glass must be evenly distributed on both sides of the panel and conveyor belts must be removed immediately from each pallet after unloading,
- the place where the glass is supported from the bottom and rear must be covered with suitable material to avoid mechanical damage, the glass should be slightly inclined from the rear (6° to 10° from the vertical) to prevent possible shifting of fire-resistant glass, the angle of 90° between the surface of the panes and the plane of support for the lower edges of the panes must be maintained,
- glass panes packaged in boxes should always be in an upright position, both during transport and storage; under no circumstances should the box be in a horizontal position,
- storage conditions for fire-resistant glass: temperature from -5°C to +40°C, humidity: no limits for minimum humidity, maximum: 70% without condensation (at 70% humidity at 5°C dew and condensation may occur on the glass, therefore, at lower temperatures, a lower humidity is necessary to prevent condensation),

MB -78EI Fire-rated doors and technical windows installation guide

- washers and elements that protect the glass from tipping over must not damage the glass or the tape glued on its edges; it is necessary to ensure that individual glass panes are separated from each other with cork spacers,
- prior to installation, each glass pane should be inspected in detail, paying special attention to possible glass cracks, scratches and other damage /the tape on glass edges is cut, torn, peeled off/ – if such defects are found, the glass panes must be immediately returned for complaint investigation,
- after installation, the sticker should be on the outside of the building in cases where the pane is intended to be installed in a fire envelope component.

2. Requirements for building aperture

- lateral edges of the aperture should be even and perpendicular to the floor
- dimensions of the aperture should be larger than the dimensions of the frame – the 'Z' clearance between the wall and the frame on each side should be as shown in Fig. 1d,
- floor plane shall allow to open the door with the clearance specified in section 5.5.1. and shown in Fig. 26,
- floor should be covered with hard and flat material (concrete, tiles, parquet).

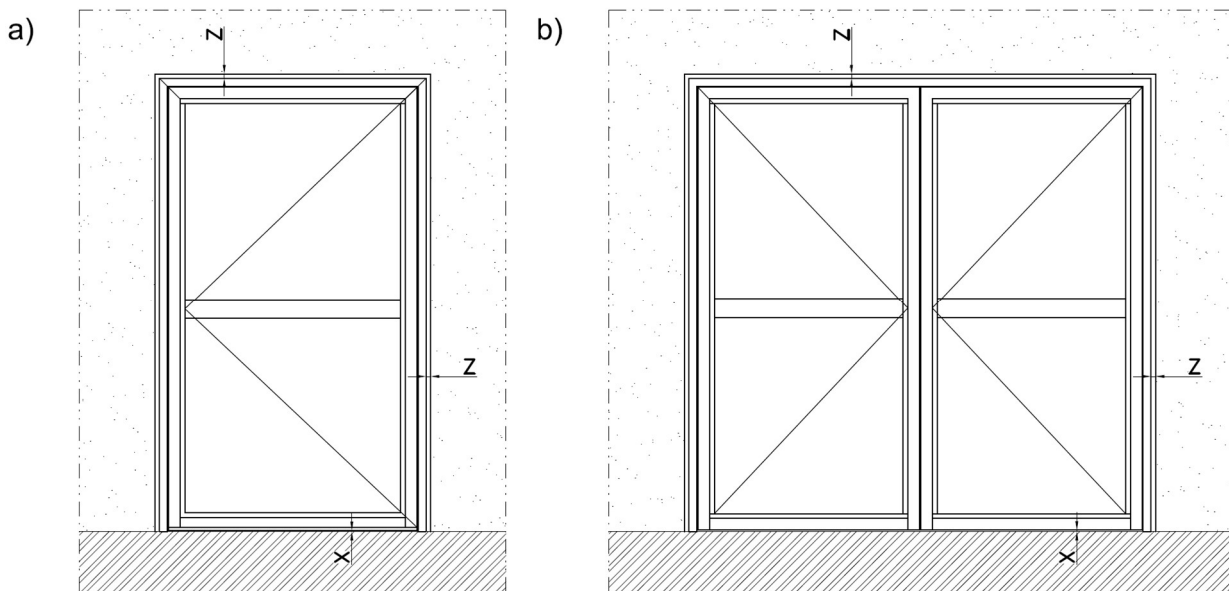

Fire resistance class	'Z' clearance dimensions [mm]
-----------------------	---------------------------------

MB -78EI Fire-rated doors and technical windows installation guide

EI 30	20-25
EI60	20-25
EI90	15-20

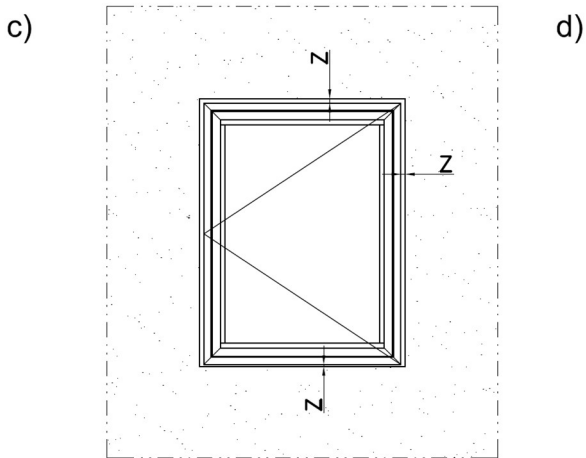

X – clearance dimensions for the lower door stop are shown in Figs. 26 and 27

Fig.1. Standard 'Z' clearance between wall frame and fire-rated door frame or fire-rated technical window frame

3. Different types of ALUPROF MB 78 EI partitions

Depending on the types of infills and cooling inserts used in profiles, we can distinguish the following types and classes of fire partitions:

- **ALUPROF MB - 78 EI₂30/EW30/E30,**
- **ALUPROF MB - 78 EI₂60/EW60/E60,**
- **ALUPROF MB - 78 EI₂90/EW90/E90.**

For the following doors and technical windows: **ALUPROF MB-78 EI₂30/EW30/E30**, profiles are insulated by variants:

- in the middle chamber – with insulating inserts made of type F plasterboards, Fig. 2 column A
- or, in the middle chamber – with CI inserts: Fig. 2, column A.

For the following doors and technical windows: **ALUPROF MB-78 EI₂60/EW60/E60**, profiles are insulated by variants:

- in all 3 chambers – with insulating inserts made of type F plasterboards, Fig. 2, column B,
- or, in the middle chamber – with CI inserts: Fig. 2, column B.

For the following doors and technical windows: **ALUPROF MB-78 EI₂90/EW90/E90**, profiles are insulated in all 3 chambers with type CI inserts: Fig. 2, column C.

MB -78EI Fire-rated doors and technical windows installation guide

The sections of the main profiles shown in Fig. 2 allow to identify fire resistance classes of the elements delivered unassembled to the construction site.

	FIRE RESISTANCE – CLASSIFICATION TIME				
	A (EI 30)		B (EI 60)		C (EI 90)
	GKF	CI insulators	GKF	CI insulators	CI insulators
K218142K					
K218140K					
K218143K					
K218141K					
K218130K					
K218200K					

Fig. 2. Insulation of ALUPROF MB-78EI system profiles according to fire resistance class

4. Conditions and guidelines for the installation of ALUPROF MB-78 EI fire doors and technical windows

The absolute rule for integration of fire-rated doors and technical windows in building walls apertures or other walls, for example, mullion and transom MB-78 EI walls or curtain walls, is the requirement that the fire resistance of these walls must not be lower than the resistance of fire partitions that are being integrated. Types of building wall constructions, materials building walls are made of as well as minimum dimensions of building walls in which ALUPROF MB-78 EI fire-rated doors and technical windows are built in, are presented in section 4.1.

4.1. Permitted door and technical windows connections with the building construction

In order to maintain the required fire resistance class, ALUPROF MB 78 EI doors and technical windows can be installed in the following building walls (building apertures):

A) ALUPROF MB 78EI30 fire partitions, i.e. fire doors and technical windows rated EI30 and/or smoke-rated S_a , S_{200} according to PN EN 13501:2016, should be integrated in walls with a fire

MB -78EI Fire-rated doors and technical windows installation guide

resistance class that is not lower than the fire resistance class of these partitions, with the following characteristics:

- solid brick walls, not less than 120 mm thick and of min. 650 kg/m³ density,
- concrete and reinforced concrete walls not less than 120 mm thick and of min. 650 kg/m³ density
- brick walls made of cavity bricks (perforated brick, checker brick) hollow silicate bricks or cellular concrete of a min. density of 650 kg/m³ and a thickness of not less than 120 mm,
- min. 105 mm-thick framed walls made of type F plasterboards, with load-bearing structure made of steel profiles
- fire walls made of ALUPROF MB 78EI aluminium profiles solution
- fire walls made of ALUPROF MB-SR50N EI aluminium profiles solution

B) ALUPROF MB-78EI60 fire partitions, i.e.: fire doors and technical windows rated EI60 and/or smoke-rated S_a, S₂₀₀ to PN EN 13501-2 :2016 should be integrated in walls with a fire resistance class that is not lower than the fire resistance class of these partitions, with the following characteristics:

- solid brick walls, not less than 175 mm thick, of a min. density of 650 kg/m³,
- concrete and reinforced concrete walls not less than 175 mm thick, of a min. density of 650 kg/m³,
- brick walls made of cavity bricks (perforated brick, checker brick) hollow silicate bricks or cellular concrete of a min. density of 650 kg/m³ and a thickness of not less than 175 mm,
- fire walls made of ALUPROF MB-78EI60 aluminium profiles solution,
- fire walls made of ALUPROF MB-SR50N EI60 aluminium profiles solution

C) ALUPROF MB-78EI90 fire partitions, i.e.: fire doors and technical windows rated EI90 and/or smoke-rated S_a, S₂₀₀ to PN EN 13501-2 :2016 should be integrated in walls with a fire resistance class that is not lower than the fire resistance class of these partitions, with the following characteristics:

- solid brick walls, not less than 175 mm thick, of a min. density of 650 kg/m³,
- concrete and reinforced concrete walls not less than 175 mm thick, of a min. density of 650 kg/m³,
- brick walls made of cavity bricks (perforated brick, checker brick) hollow silicate bricks or cellular concrete of a min. density of 650 kg/m³ and a thickness of not less than 175 mm.

MB -78EI Fire-rated doors and technical windows installation guide

4.2. Guidance on installation of doors and technical windows

4.2.1. Installation of doors and technical windows in flexible and rigid walls

Fig.3 shows basic diagrams of anchoring dowels and bolts in walls made of various building materials along with dimensional relationships (the diagrams refer to every fire resistance class).

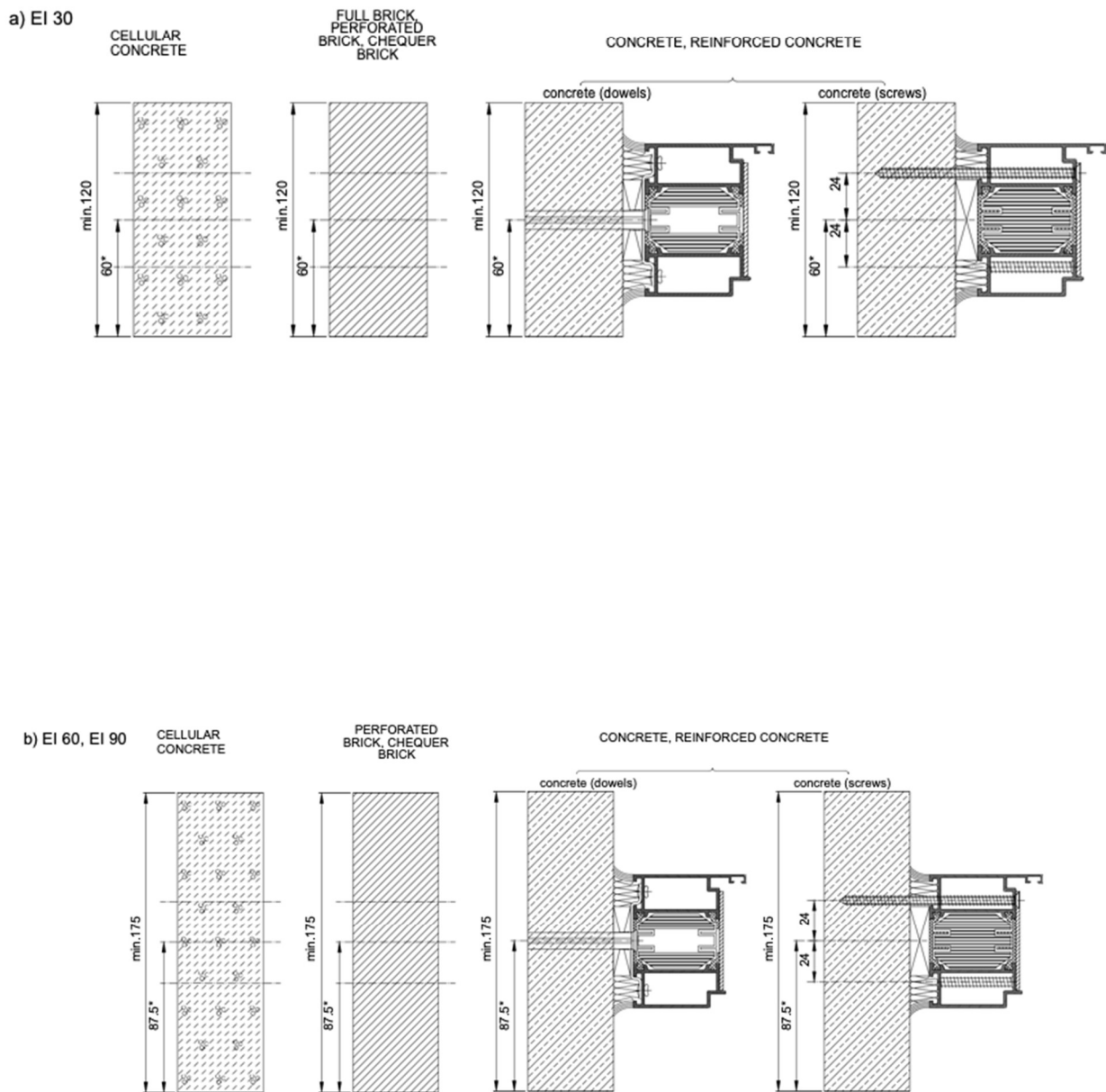

Fig.3. Recommended distance of dowels and screws from the edge of the frame for walls made of various building materials (required wall density: min. 650kg/m³)

MB -78EI Fire-rated doors and technical windows installation guide

Variants of installing the frames of ALUPROF MB-78EI doors and windows can include the use of the fixing elements listed in Table 1 below:

Table 1

Elements fixing doors and technical windows w rigid and flexible walls

Door or technical window fire resistance class	Name of fixing element	Fixing element catalogue number	Maximum spacing of fixing elements [mm]	
			from frame corner	between subsequent building apertures
Rigid walls				
EI30, EI60	- system-specific anchor, - steel expansion plug	80322086 min ϕ 10 x 80 mm	250	600
	- mounting plate, - steel rivet ϕ 4 mm, - steel expansion plug	80322073 80377106 min ϕ 10 x 80 mm	250	600
EI90	- system-specific anchor, - steel expansion plug	80322086 min ϕ 10 x 80 mm	150	300
	- mounting plate, - steel rivet ϕ 4 mm, - steel expansion plug	80322073 80377106 min ϕ 10 x 80 mm	150	300
Flexible walls GKF				
EI30	- system-specific anchor, - steel expansion plug	80322086 min ϕ 10 x 80 mm	250	600
	- mounting plate, - steel rivet ϕ 4 mm, - steel expansion plug	80322073 80377106 min ϕ 10 x 80 mm	250	600

4.2.2. Installation of doors and windows in walls made of ALUPROF MB-78EI profiles

Fire doors and technical windows rated EI30 and EI60 can be installed in ALUPROF MB-78EI walls.

ALUPROF MB-78EI wall requires preparing the edging strip (catalogue no. K518139X) of the door frame, fixed with ϕ 4,8 x 22 mm steel screws (catalogue no. 87222506) to mullions and bars of the wall construction, spaced at no more than 150 mm. Installation in walls is described in section 5.3. and shown in Figs. 22-24.

4.2.3. Installation of doors and technical windows in ALUPROF MB-SR50N EI filling walls

Fire doors and technical windows rated EI30 and EI60 can be installed in ALUPROF MB –SR50N EI filling walls as shown in Fig. 25 and described below.

Door frames are installed directly in ALUPROF MB-SR50N EI mullions with the use of the aluminium profile, catalogue no. K418023X and ϕ 4,8x 16 mm screws (catalogue no. 87222504), spaced at no more than 150 mm. The gap between profiles is filled with a cooling insert (catalogue no. 80462196).

4.3. Dimensions of ALUPROF MB-78 EI fire partitions and construction possibilities

4.3.1. Fire construction types and maximum partition size

MB -78EI Fire-rated doors and technical windows installation guide

Figs. 4-7 show fire partitions diagrams of ALUPROF MB 78 EI technical solution with their authorised dimensions. Figs. 8-12 show possible arrangements of doors with upper and side panels based on the report on the decision to extend the scope of using fire test results to PN-EN +A1:2016.

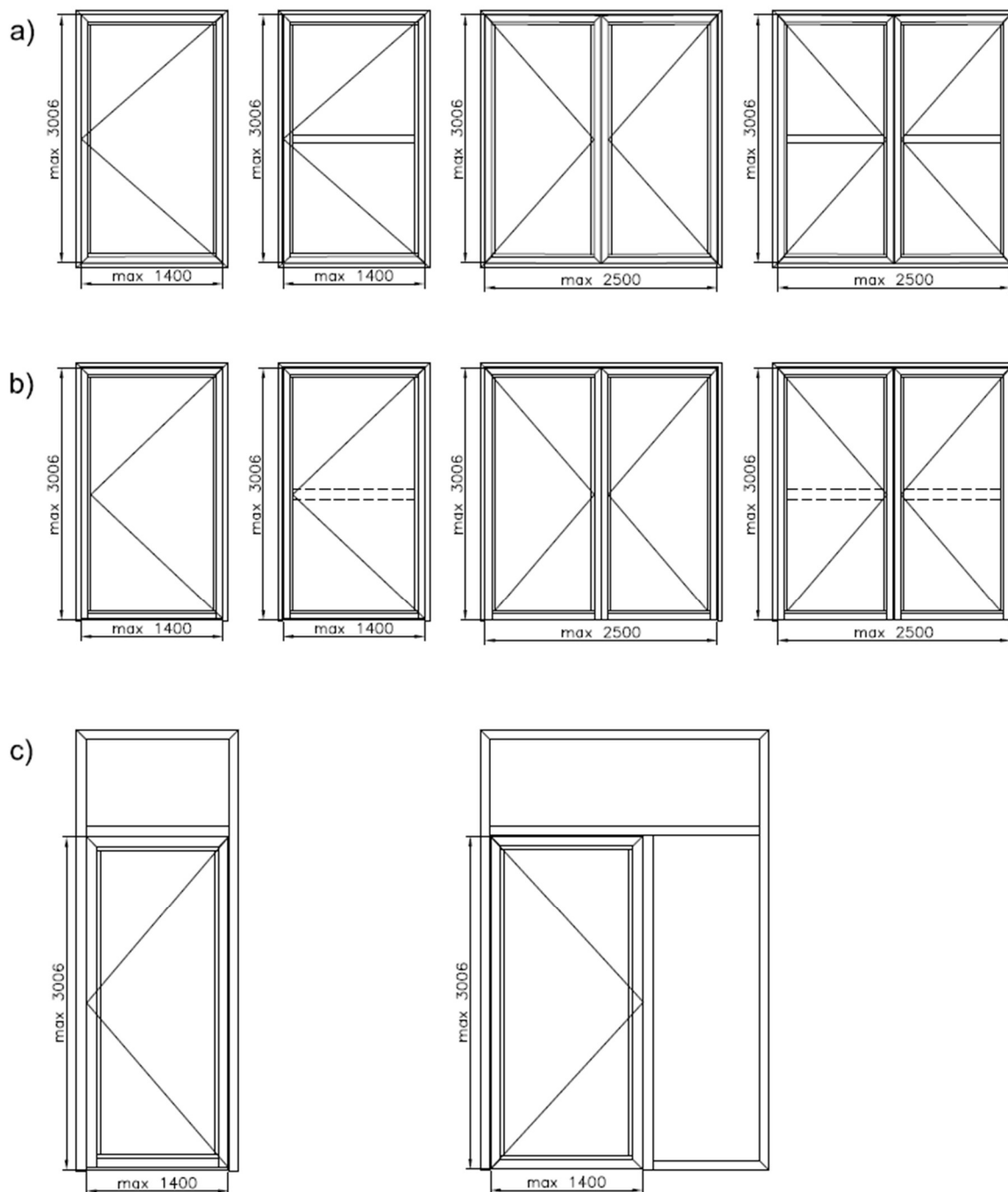

**Fig. 4 Types of fire constructions rated EI30 and leaf maximum dimensions:
a) technical windows; b) doors; c) door systems**

MB -78EI Fire-rated doors and technical windows installation guide

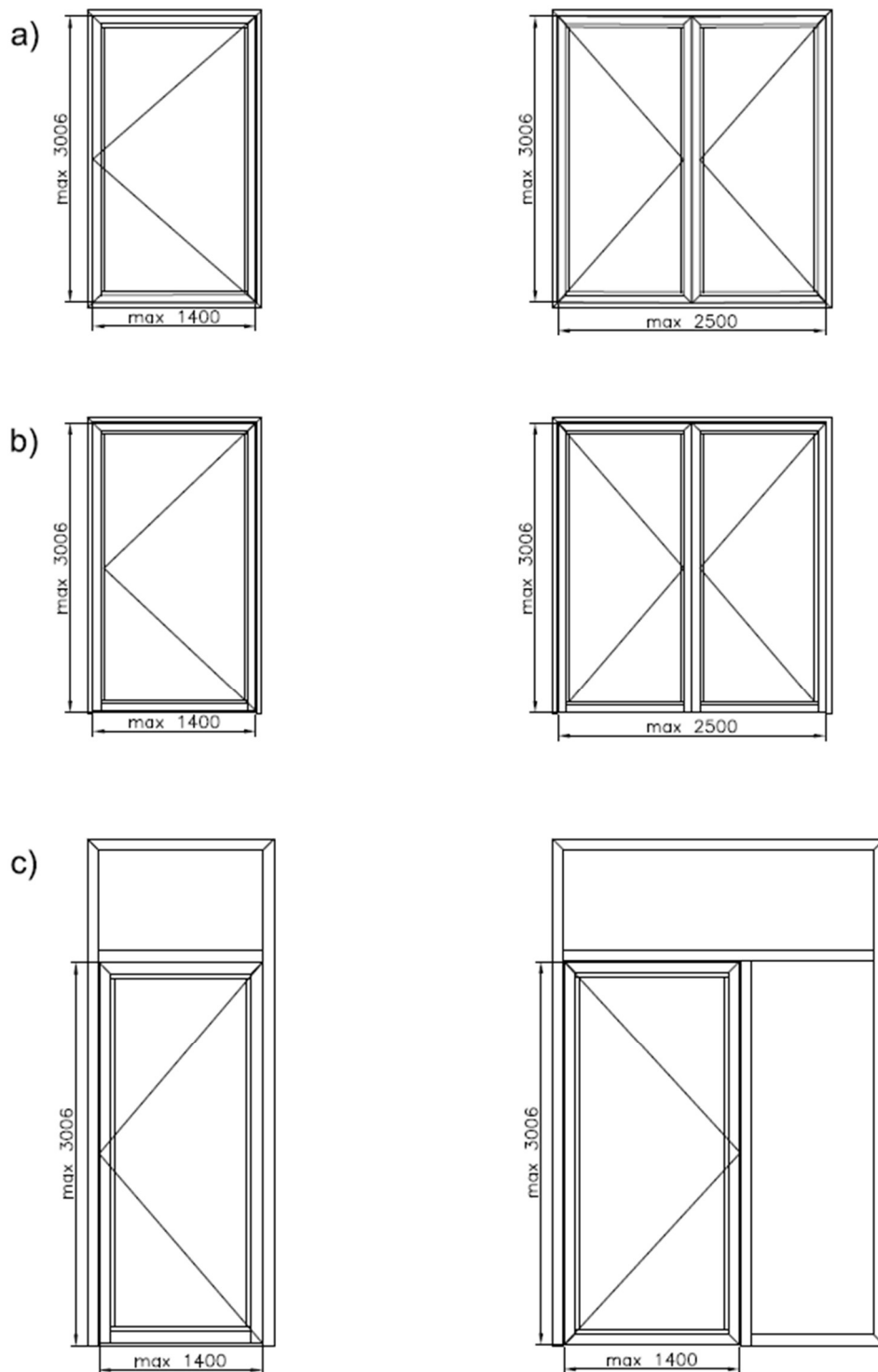

**Fig. 5 Types of fire constructions rated EI60 and leaf maximum dimensions:
a) technical windows; b) doors; c) door systems**

MB -78EI Fire-rated doors and technical windows installation guide

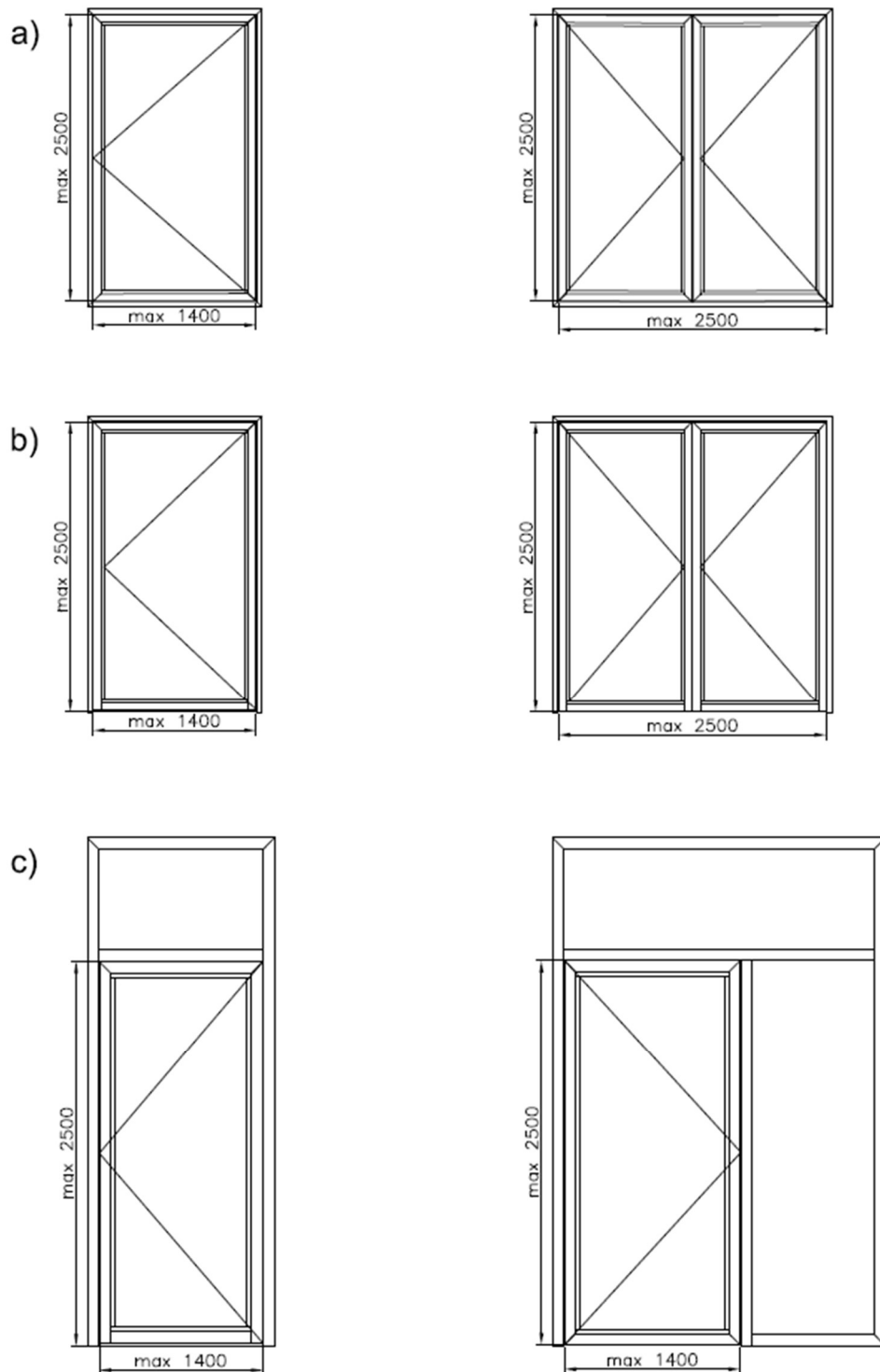

**Fig. 6 Types of fire constructions rated EI90 and leaf maximum dimensions:
a) technical windows; b) doors; c) door systems**

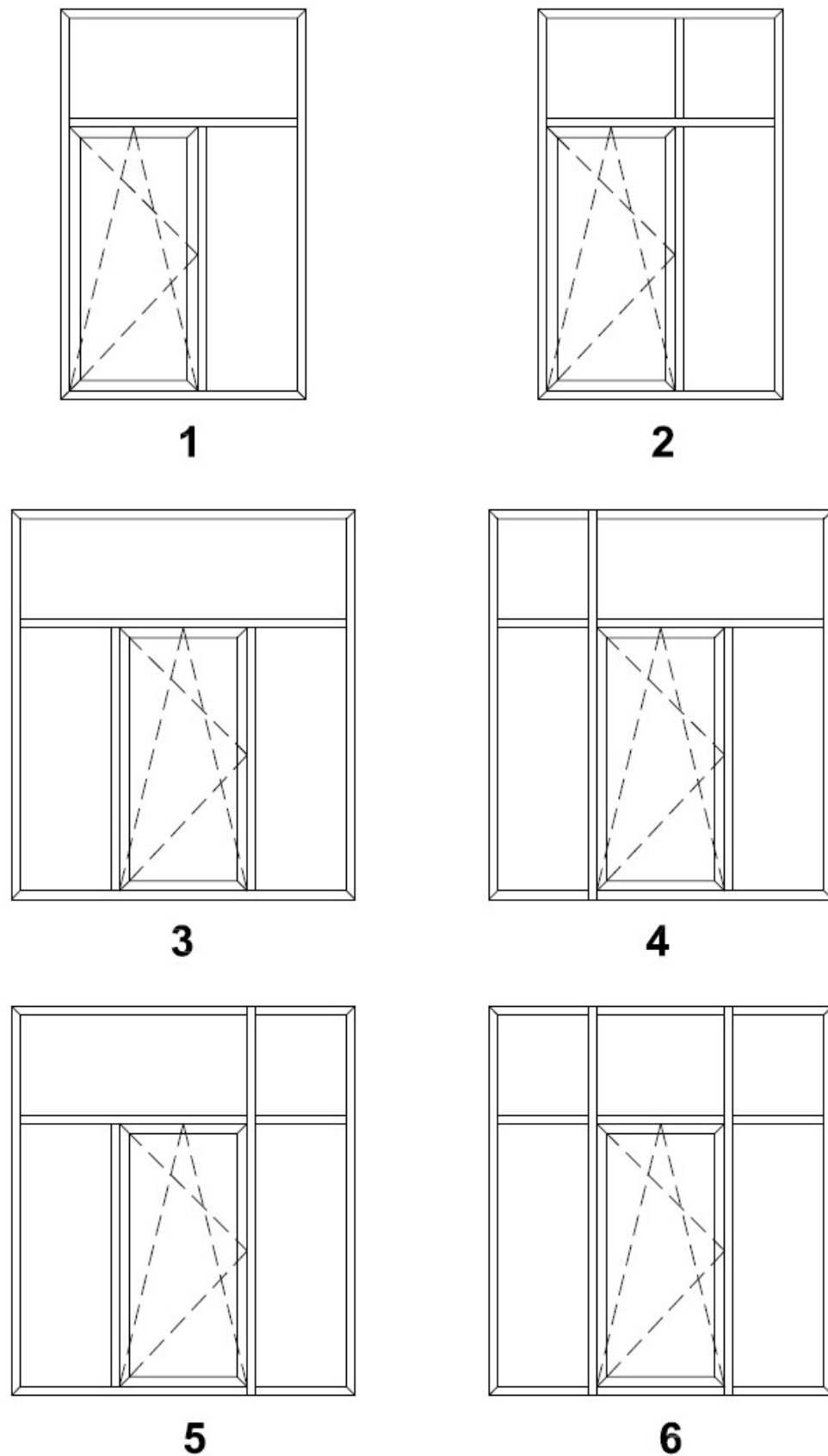
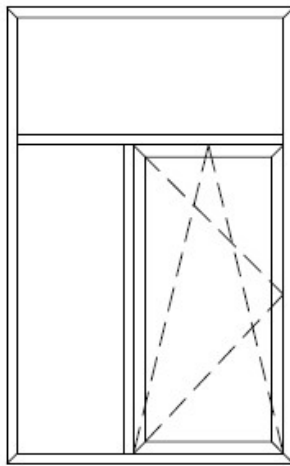
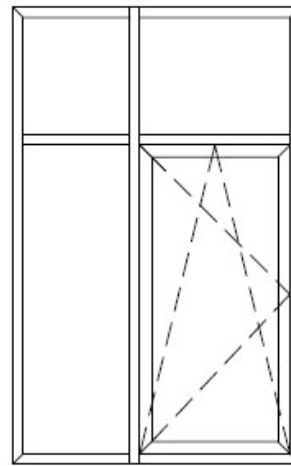

Fig. 7 Permissible ALUPROF MB-78EI door system structures – type EI 30, EI 60 and EI 90 (part 1/5)



7



8

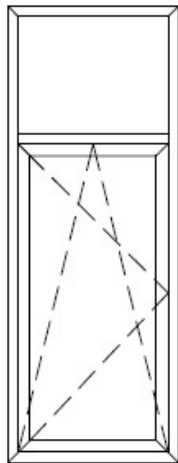

9

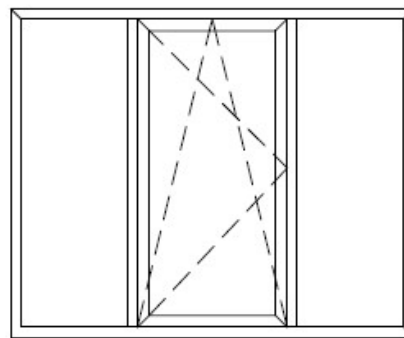

10

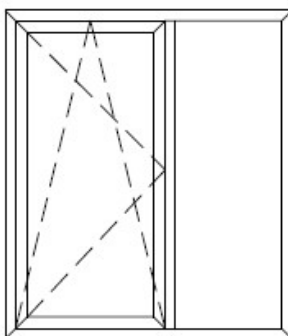

11

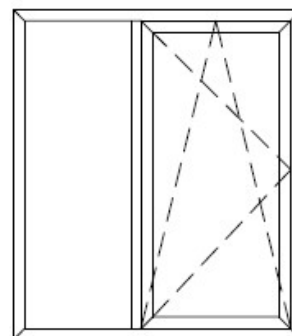

12

**Fig. 8 Permissible ALUPROF MB-78EI door system structures – type EI 30, EI 60 and EI 90
(part 2/5)**

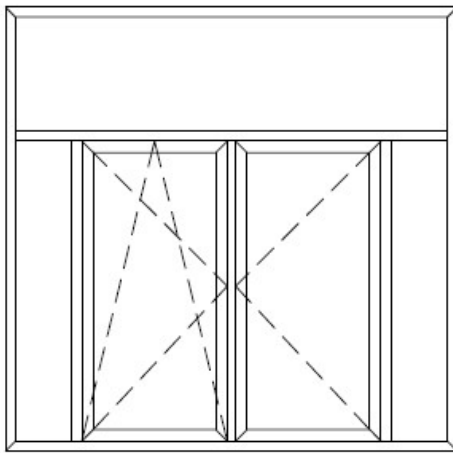

13

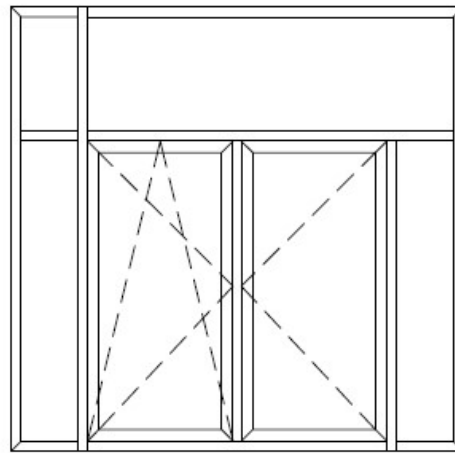

14

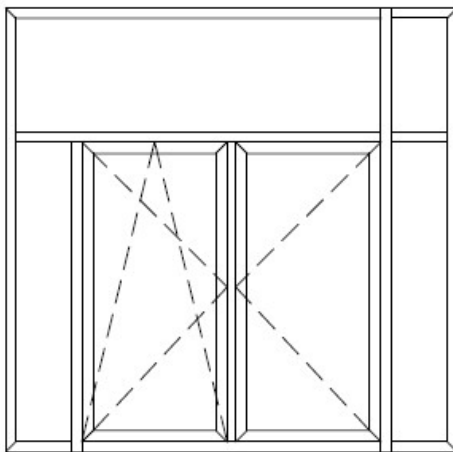

15

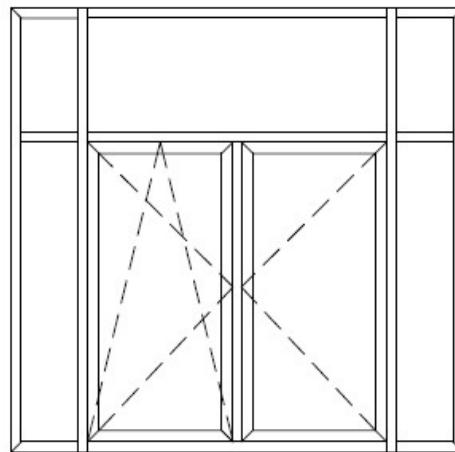

16

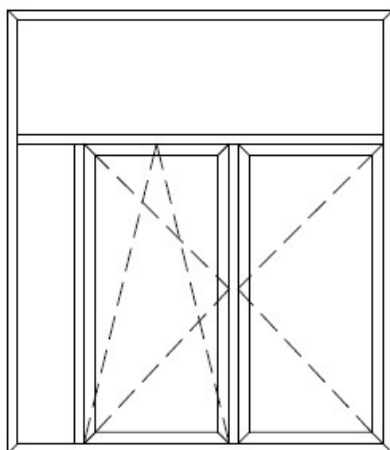

17

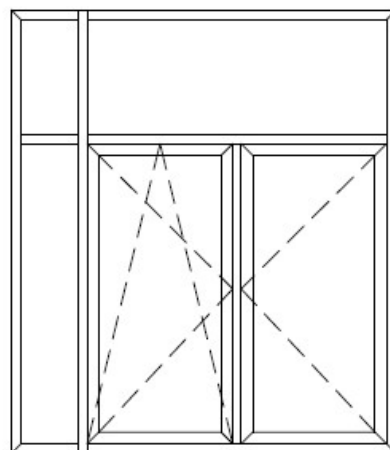

18

Fig. 9 Permissible ALUPROF MB-78EI door system structures – type EI 30, EI 60 and EI 90 (part 3/5)

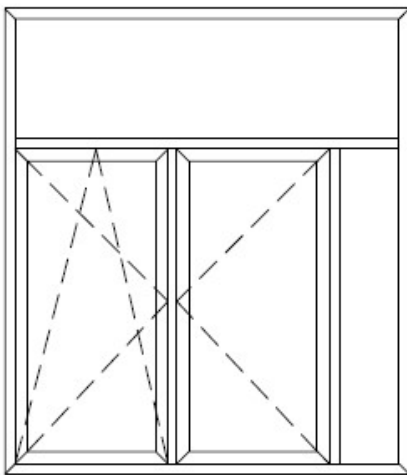

19

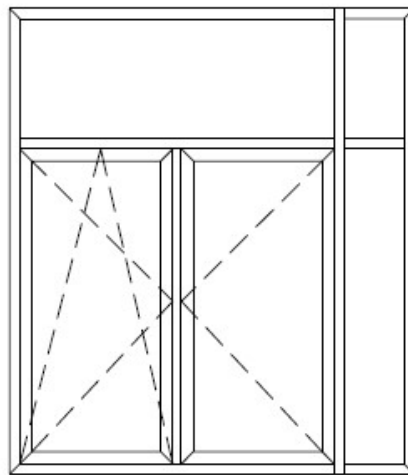

20

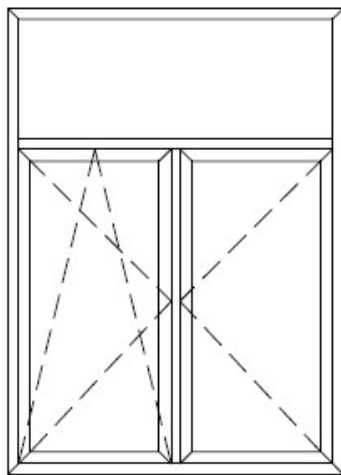

21

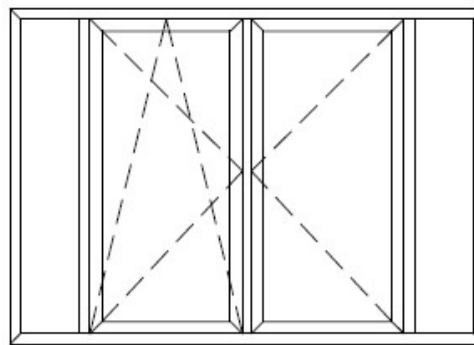

22

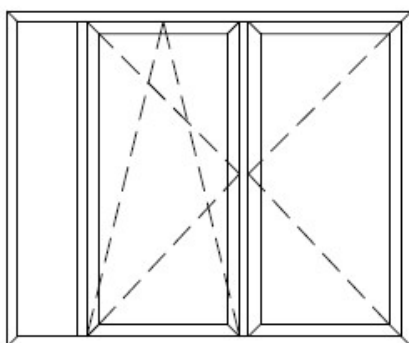

23

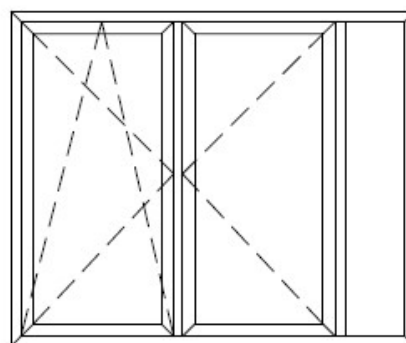

24

Fig. 10 Permissible ALUPROF MB-78EI door system structures – type EI 30, EI 60 and EI 90 (part 4/5)

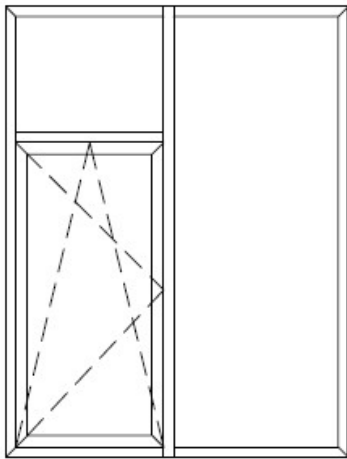

25

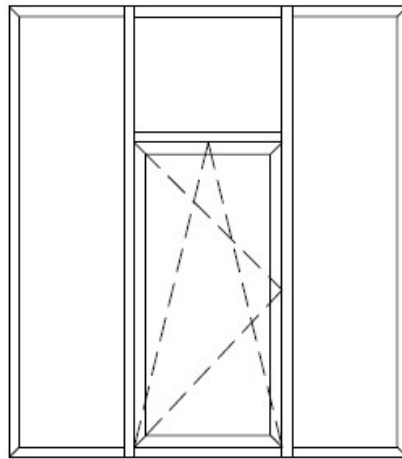

26

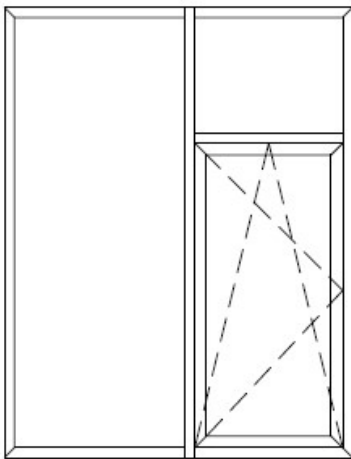

27

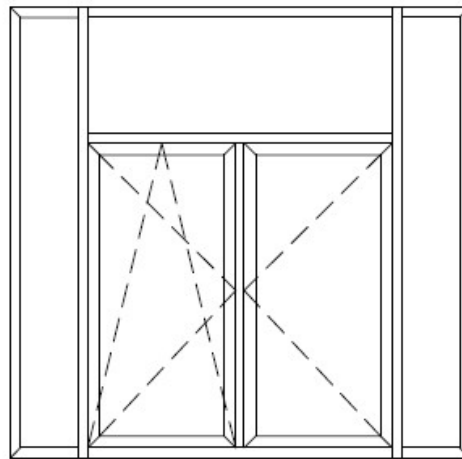

28

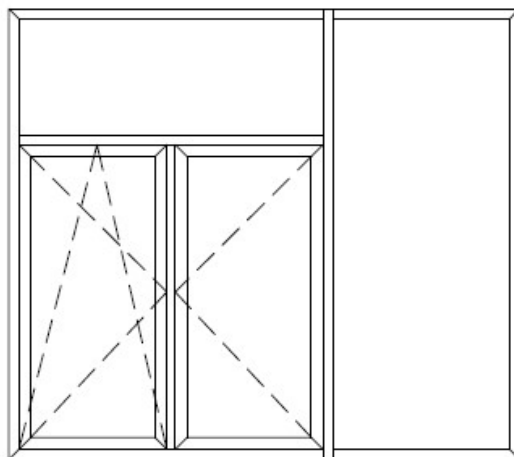

29

Fig. 11 Permissible ALUPROF MB-78EI door system structures – type EI 30, EI 60 and EI 90 (part 5/5)

4.3.2. Relationships between dimensions of fire-rated ALUPROF MB-78 EI doors and dimensions of mounting holes

Figures 12-15 show the dimensional specification of the installation of MB – 78EI door types based on the classifications of permissible, minimum and maximum door leaf dimensions for all fire resistance classes.

MB -78EI Fire-rated doors and technical windows installation guide

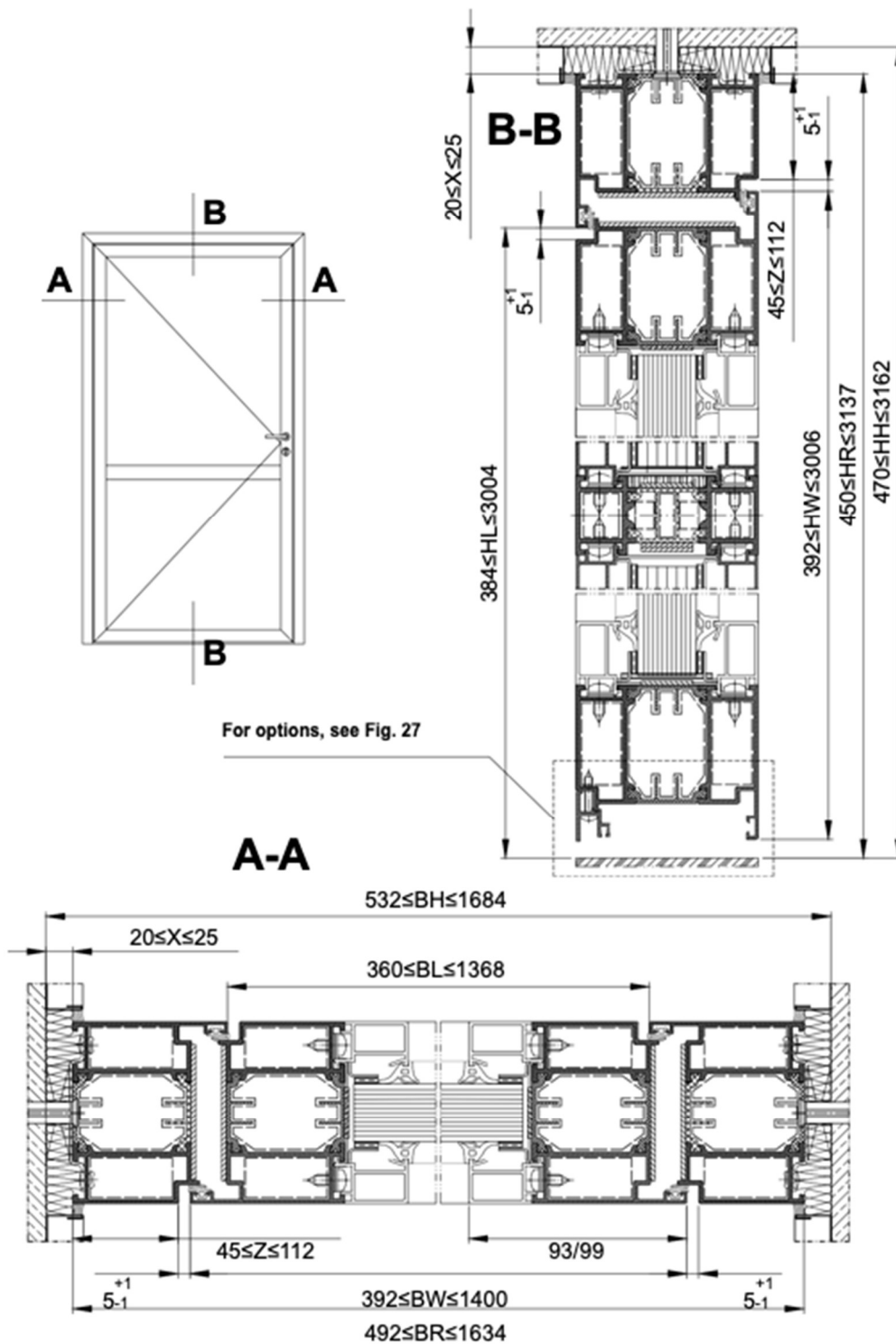

Fig. 12 Dimensional specification of the installation of single door MB-78 EI30 and MB-78 EI60

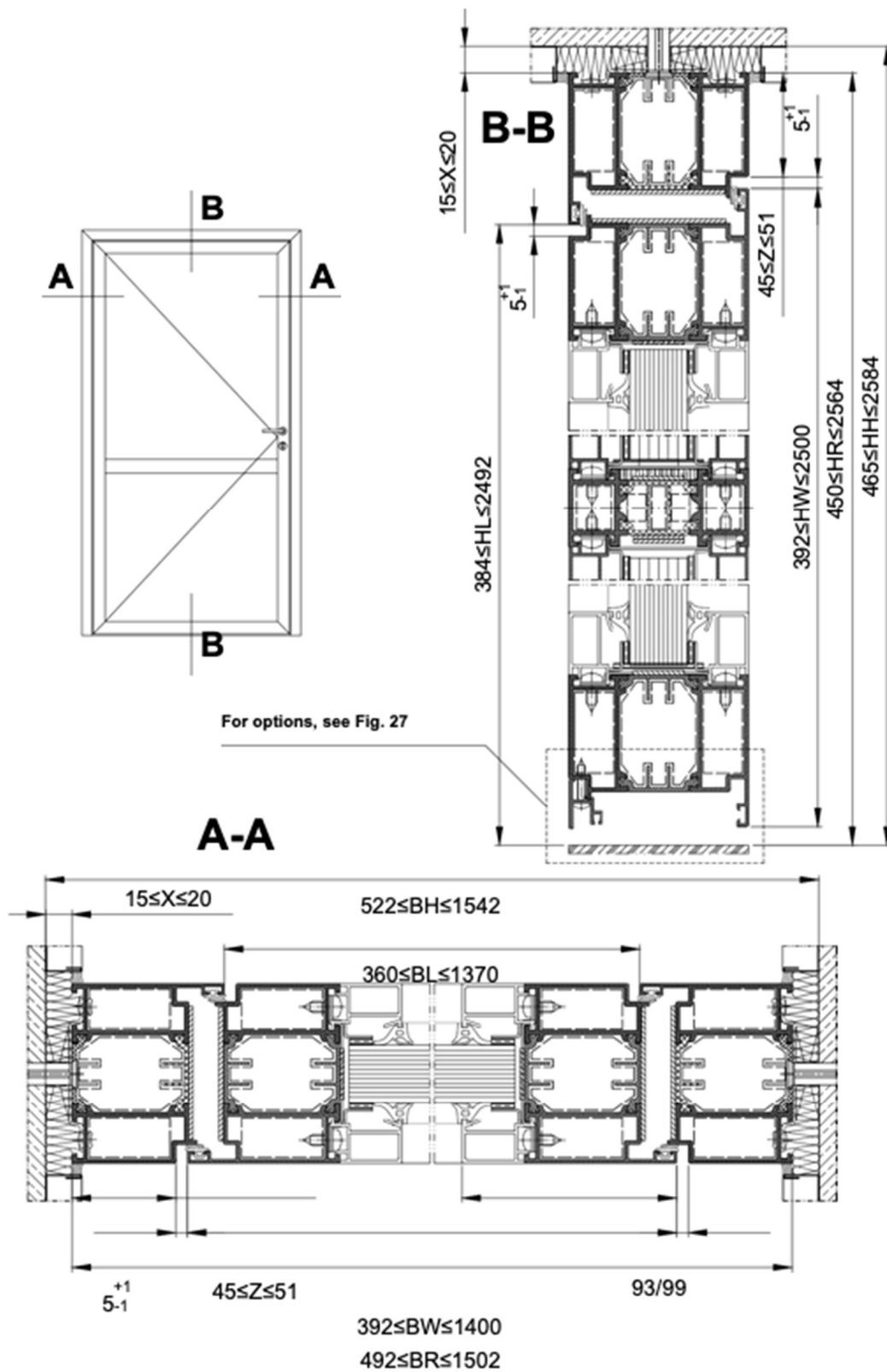

Fig. 13 Dimensional specification of the installation of single door MB-78 EI90

MB -78EI Fire-rated doors and technical windows installation guide

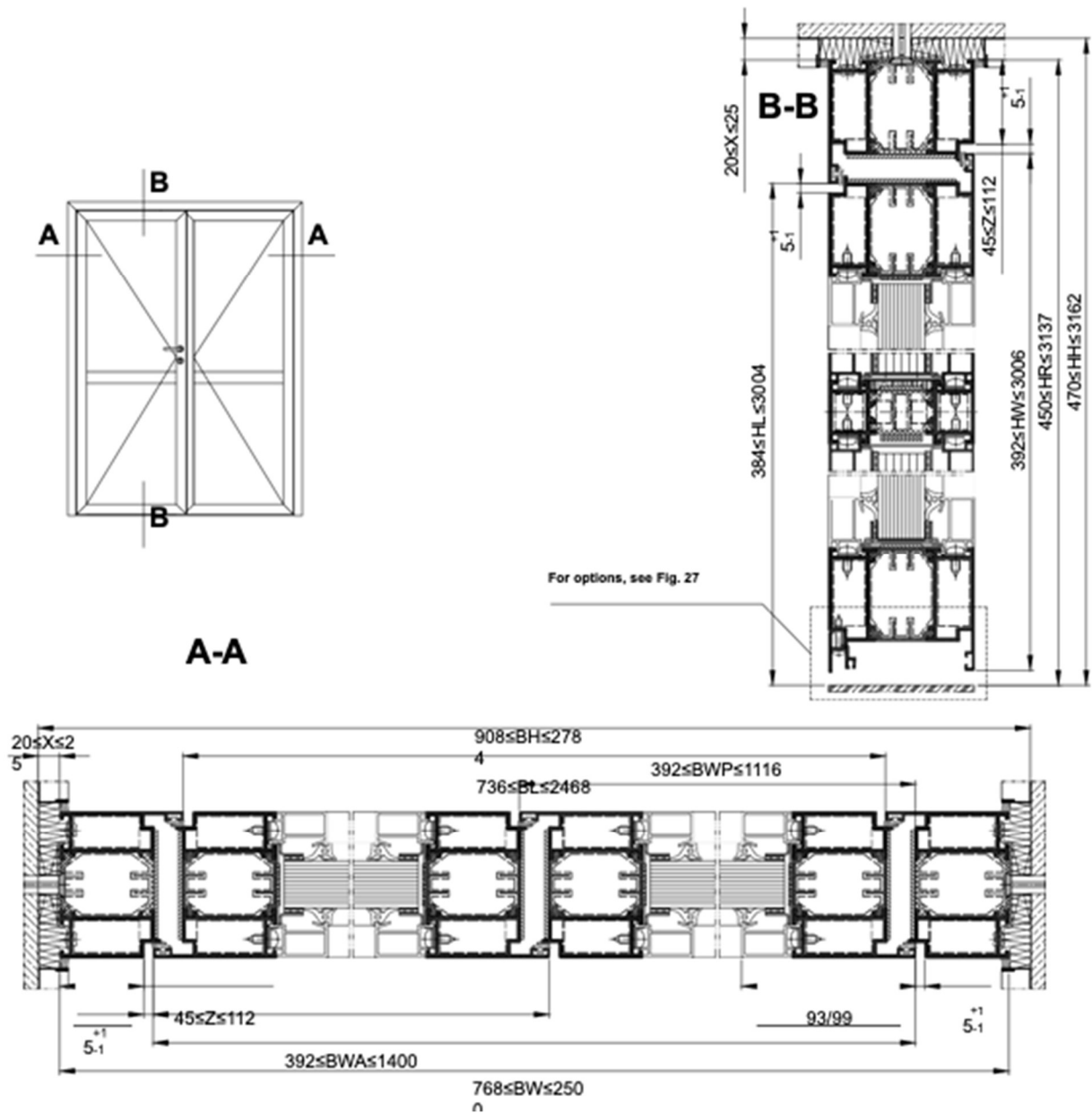

Fig. 14 Dimensional specification of the installation of single door MB-78 EI30 and MB-78 EI60

MB -78EI Fire-rated doors and technical windows installation guide

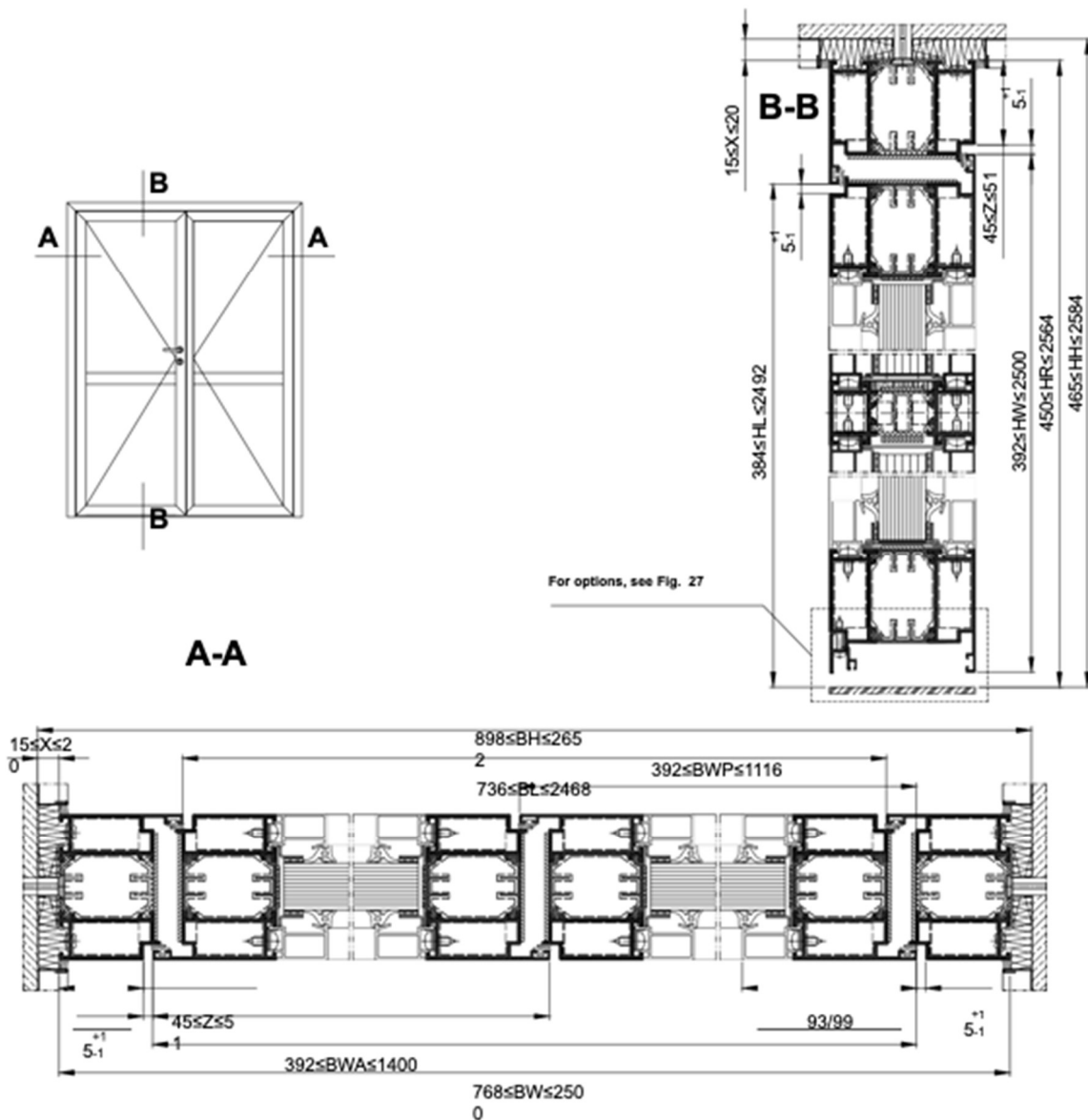

Fig. 15 Dimensional specification of the installation of single door MB-78 EI90

MB -78EI Fire-rated doors and technical windows installation guide

4.3.3. Dimensional specification of fixing points in ALUPROF MB 78 EI fire doors and technical windows

Fig. 16 shows the dimensional data of fixing points in door and technical window frames for all fire resistance classes.

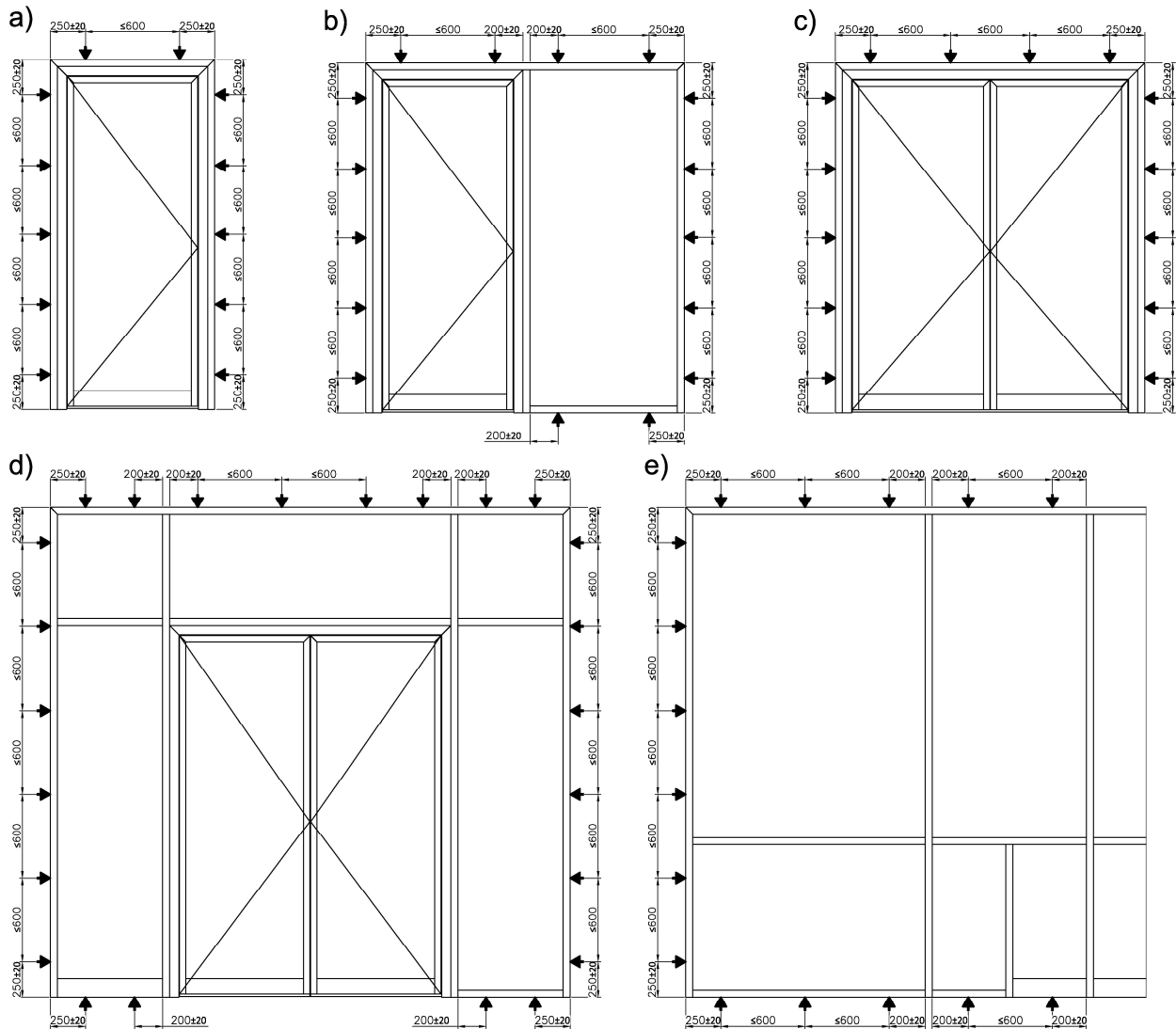

Fig. 16 Dimensional data of fixing points in MB-78EI door and technical window frames for all fire resistance classes

Fig. 17 shows the principle for fixing frame with steel concrete screws and other ceramic materials, while Fig. 18 shows the arrangement of fixing points and installation of system-specific fixing elements (catalogue no. 80322073 or 80322073).

MB -78EI Fire-rated doors and technical windows installation guide

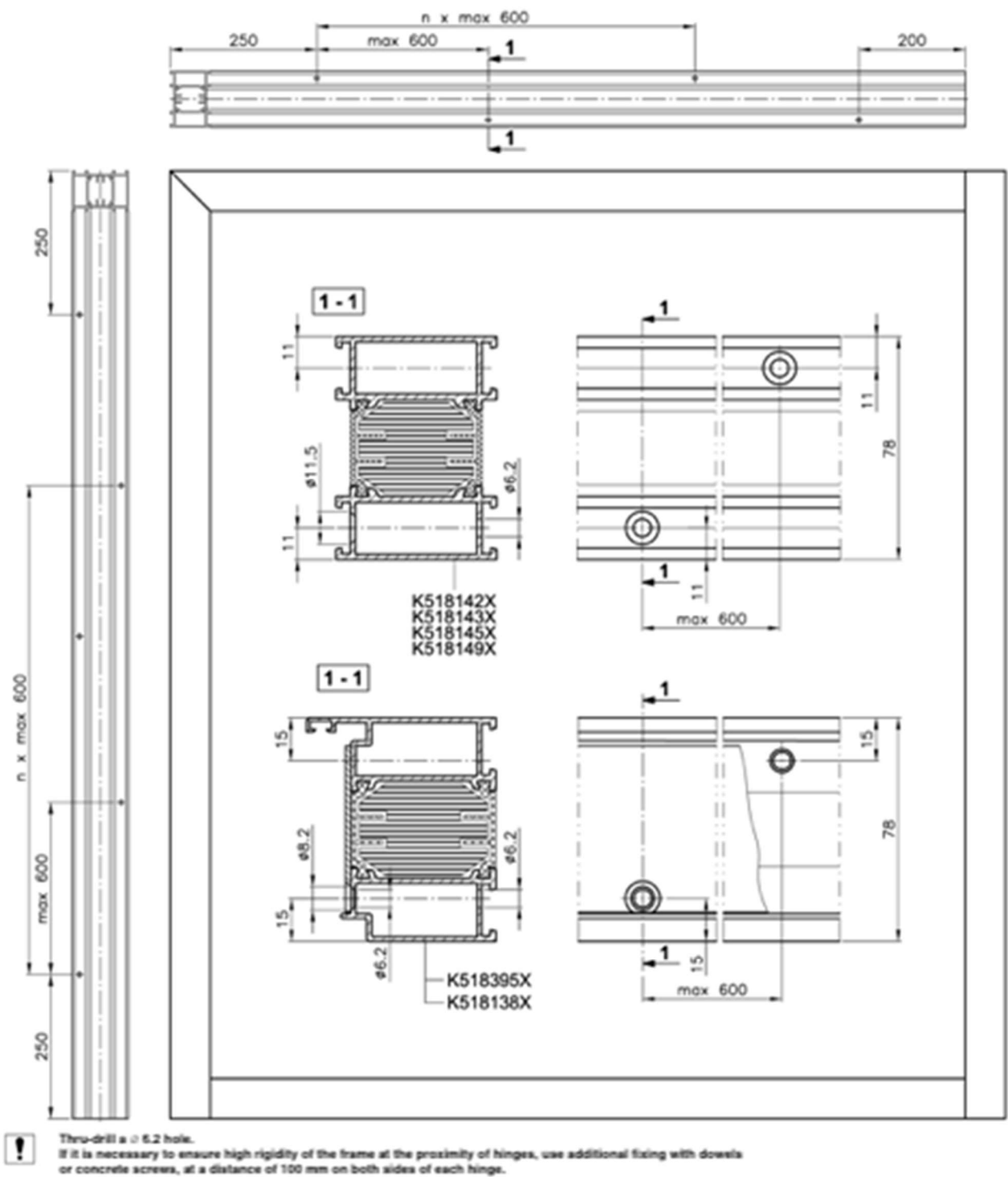
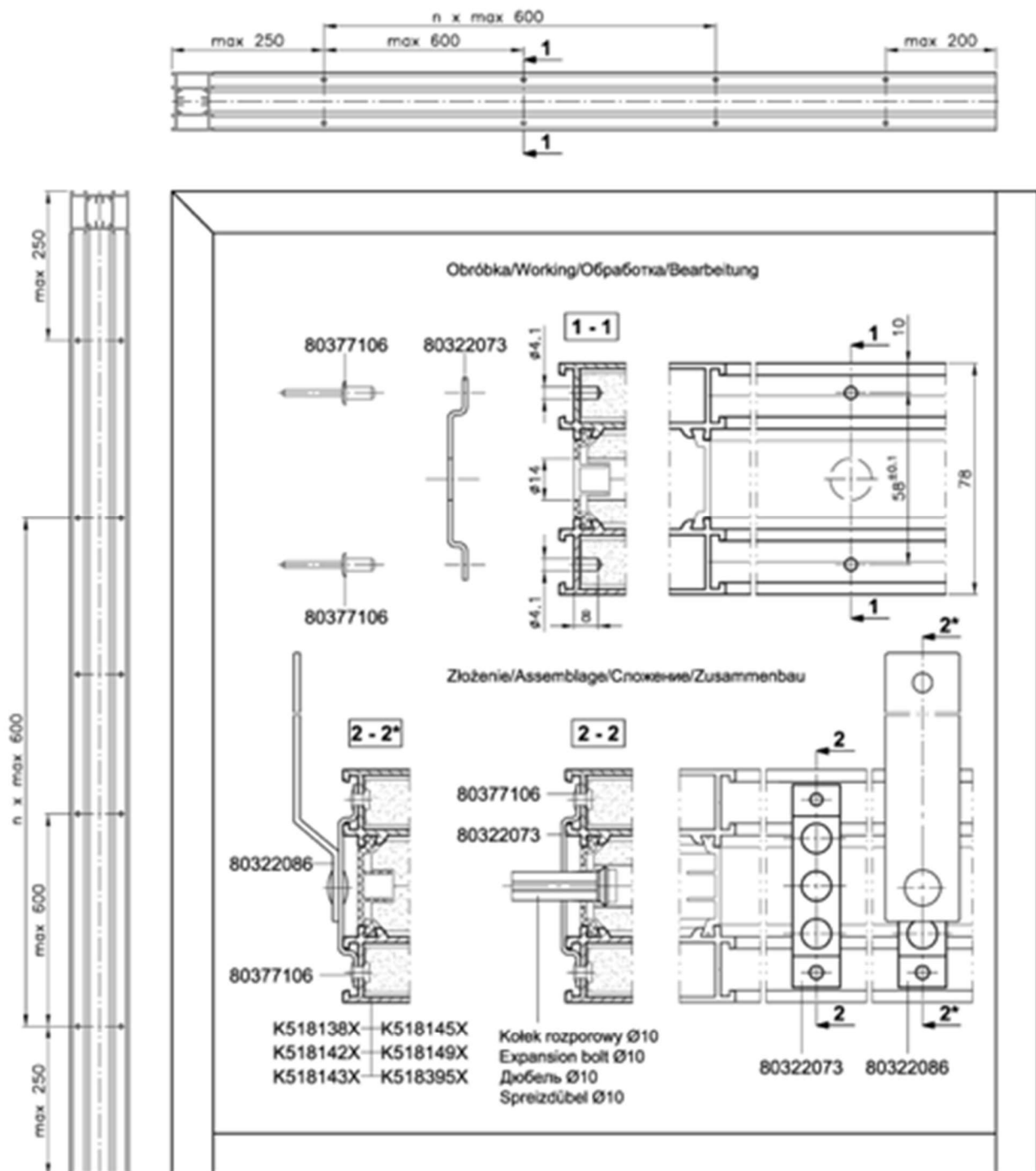

Fig. 17 Preparation of frames for fixing to the building structure using concrete screws

MB -78EI Fire-rated doors and technical windows installation guide



Thru-drill a $\varnothing 14$ hole when fixing with expansion bolts. Drill a $\varnothing 4.1$ hole using the device P3K-837-03.
If it is necessary to ensure high rigidity of the frame at the proximity of hinges, use additional fixing with dowels or concrete screws, at a distance of 100 mm on both sides of each hinge.

Fig. 18 Preparation of frames for fixing to the building structure using system elements 80322073 or 80322086

MB -78EI Fire-rated doors and technical windows installation guide

5. Installation

- ALUPROF MB 78 EI glazed aluminium fire partitions of doors and technical windows may be installed in apertures and building walls with characteristics listed in section 4.1. with the use of fixing elements listed in section 4.2.
- each wall into which fire partitions are embedded shall be of a fire resistance class that is not less than the fire partition being embedded in it,
- fire partitions should be installed at a temperature not lower than 5⁰C, and the surfaces of the construction should be protected with a protective foil against external factors such as water, dust or mortar,
- door or window frame without leaves or door system frame should be placed in the aperture and then secured with wedges and nogging pieces. Adjust the level of the upper transom and the verticality of the side mullions of the frame in turn, by correcting their position with wedges. Right angles should be checked using an angle with a minimum arm length of 600 mm. At least 4 adjusting nogging pieces should be placed symmetrically over the entire door frame height and the dimensions in the frame rebate should be checked while maintaining the same width across the entire frame height. It is also necessary to check the depth of the frame or door system frame from the outer or inner face of the building wall,
- the maximum permissible installation deviations are:
 - angle deviation in the corners of the frame: $\pm 0,025^\circ$
 - deviation of frame mullions/posts from the vertical: ± 0.25 mm /m,
 - departure from flatness or ripples are not allowed,
- after the frame is levelled and wedged, the hinge-plane of the frame should be pre-anchored at 2 - 3 locations without fully tightening the dowels, screws or bolts,
- at the fixing point, hardwood or metal washers must be placed in the gap between the wall and the frame to prevent the frame from being “pulled in” when tightening dowels, screws or bolts, the thickness of the washers should guarantee the appropriate size of the gap between the frame aperture and frame as shown in Fig. 1, for each fire resistance class respectively,
- for doors or technical windows, the leaf must be placed in the frame and the clearance between the leaf and the frame, and between the leaf and the floor must be checked, the gaps must be equal and their size must be in accordance with section 5.5.1 ; 5.5.2 ; 5.5.3 and with drawings 26 and 27,
- if the clearance dimensions are correct, drill the holes for other fixings and tighten the dowels or bolts,
- after tightening the dowels, bolts or screws, check the clearance again and then check the adherence of the leaf to the frame, if the leaf does not adhere evenly to the frame, make the necessary corrections on the hinges. It should be remembered that the position of the leaf in relation to the frame must not be changed by exceeding the permissible tolerance for hinge adjustment – hinge adjustment must not compensate for frame installation errors and imperfections,

MB -78EI Fire-rated doors and technical windows installation guide

- after this operation, the leaf should be removed and the gaps between the building aperture and the frame/fire wall frame should be filled in as shown in Figs. 19,21,27.
- After the filling has hardened, remove the spacers, fill in the places where they were located, and then proceed to finish the aperture and hang the leaf/leaves,
- the door leaf should move smoothly and without jams and the door closer should brake and tighten the leaf before closing.

5.1. Installation of ALUPROF MB - 78EI doors, windows and door assemblies in walls made of ceramic materials

5.1.1. Installing single or double leaf door or technical window frame

- if the frames are installed in building walls made of ceramic materials described in section 4.1. A, B, C, check the type of materials and the minimum wall thickness,
- if different doors are installed in series, they should be separated by a pillar, which should have the same characteristics as the main building wall,
- the sides of the frame should be fitted with frame connector (catalogue no. 80322073) or frame connector with anchor (catalogue number 80322086) in sufficient quantities and spaced in accordance with section 4.2.1. and 4.3.3. and Figs. 16 and 18, or, if they are fixed with the use of concrete screws, as shown in Figs. 16 and 17,
- the frame should be placed vertically to the floor and perpendicularly to the reveal,
- the following “Z” clearances shall be maintained between the frame and wall: for fire partitions rated EI30 and EI60 : Z = 20 – 25 mm, for fire partitions rated EI90 : Z = 15 – 20 mm, in accordance with section 2 and Fig. 1,
- the door frame or door system frames should be fixed to the wall with at least \varnothing 10 mm steel expansion plugs, or system-specific anchors (catalogue no. 80322086), and spaced at no more than 600 mm; their distance from the corners of the frame or door system frame should not be greater than 250 mm in accordance with Figs. 16, 17 and 18.
- if the frame is fixed by means of steel anchors, the hole is to be drilled in the middle chamber of the frame and the anchor should pass through the middle hole of the frame connector (catalogue no. 80322073), and, in the case of the system-specific anchor (catalogue no. 80322086), the holes in the wall should be made through the holes in the anchor’s arm,
- fill the space between the frame and the reveal with tightly compacted mineral wool with a minimum density of 70 kg/m³
- the joint should be made by closing it with type F plasterboard/render/firestop silicone or with metal profiles,
- examples of fixing door, technical windows and door assemblies frames to the walls made of ceramic materials and concrete are shown in Figs. 3, 19 and 27.

Symbol explanations to Figs. 19, 21, 26, 27

- 1 – floor, concrete, glazed floor tiles,
- 2 – screed, levelling screed,
- 3 – concrete,
- 4 – steel angle profile 3 x 35 x 35 or 4 X40 x 40,
- 5 – concrete screw \varnothing 6 mm,
- 6 – vapour-permeable membrane, e.g. ILBRUCK,
- 7 – steel screw anchor \varnothing 10 mm
- 8 – system-specific steel anchor (catalogue no. 80322086)
- 9 – steel fastener 80322073 (catalogue no. 80322073)
- 10 – steel, threshold-connecting element (catalogue no. 80322076)
- 11 – steel threshold recessed into the floor, Inox steel, thickness 3 to 5 mm
- 12 – silicone sealant
- 13 – mineral wool minimum thickness 70 kg/m³
- 14 – insulation layer for door threshold (extruded polystyrene)
- 15 – vapour-permeable membrane, e.g. Ilbruck
- 16 – silicone sealant for the external finish
- 17 – mineral wool minimum thickness 50 kg/m³
- 18 – thermal insulation of the building wall
- 19 – plasterboard 12.5 mm
- 20 – exterior finish of the building wall
- 21 – spacer, hardwood
- 22 – fire-resistant F plasterboard 12.5 mm single or double
- 23 – steel angle profile 4 x 50 x 50
- 24 – fire-resistant F plasterboard 20 mm or Promatec H board 20 mm
- 25 – \varnothing 8 mm concrete screw
- 26 – M8 screw
- 27 – mineral wool with a thickness and density in accordance with the wall documentation
e.g. KNAUF solution

MB -78EI Fire-rated doors and technical windows installation guide

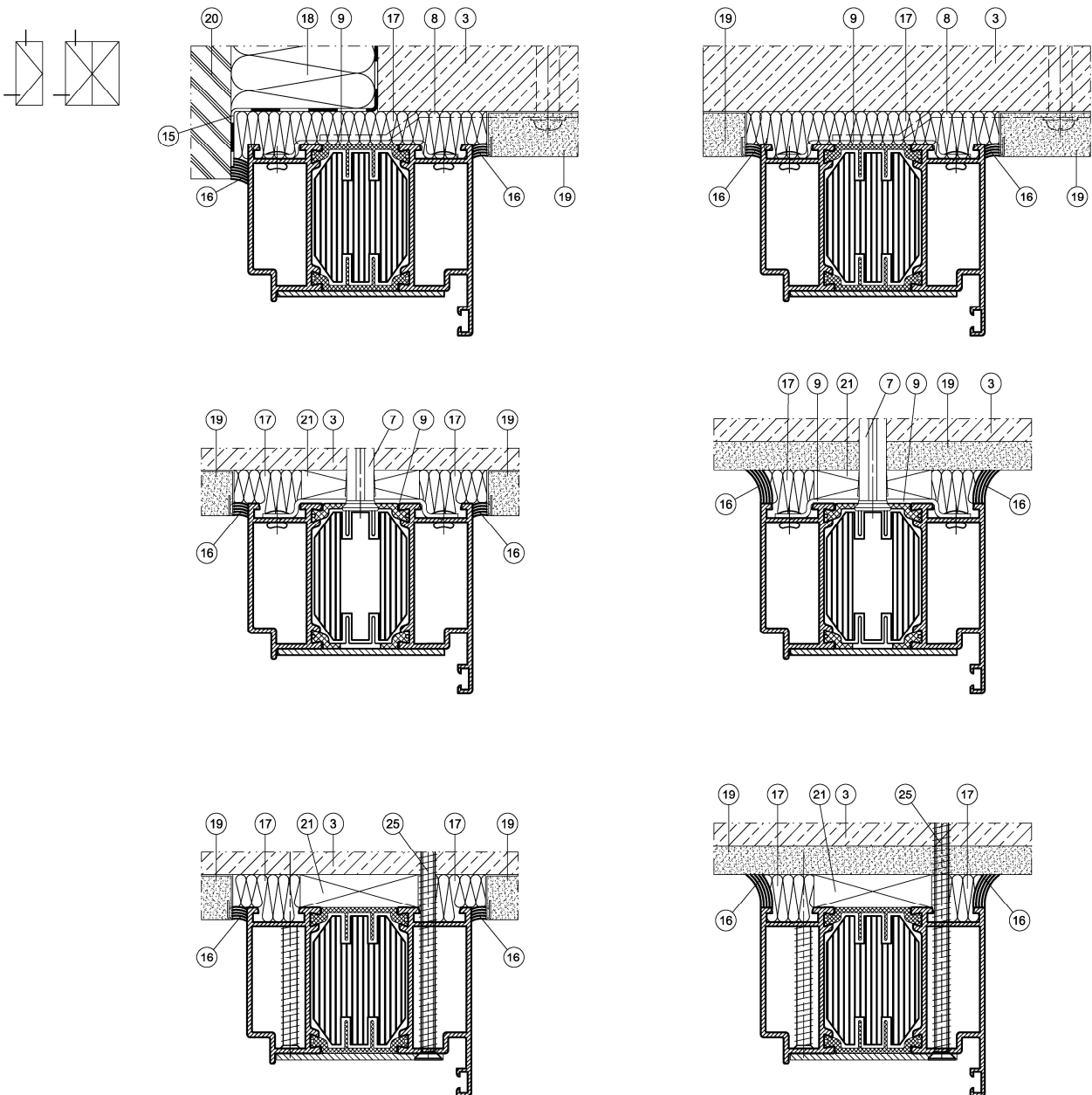

Fig. 19 Sealing variants for door/technical window/door system frame-to-building structure connection

5.1.2. Installation of door systems with top/side light in ceramic walls

- door frame with top/side light on a common frame should be attached in the same way as the door frame,
- if the embedded construction has separate doors and separate side light frames, proceed as follows:

a) variant I – fill the cavities in the frame assembly with soft mineral wool throughout the entire contact length and then screw the frames with M 8 x 16 screws through the elements (catalogue no. 80322073), spaced in accordance with section 4.2.3 and Fig. 18, in the middle chambers of the profiles, in accordance with Fig. 20 (variant I), or,

MB -78EI Fire-rated doors and technical windows installation guide

b) variant II – on one side of one of the frames, stick the 22-mm wide intumescent door seal (catalogue no. 120655) on the entire length and screw the frames with two rows of screws (catalogue no. 87252506) spaced every 400 mm in the outer chambers of the profiles, in accordance with Fig. 20 (variant II),

- carry out the remaining installation operations in accordance with section 5.1.1

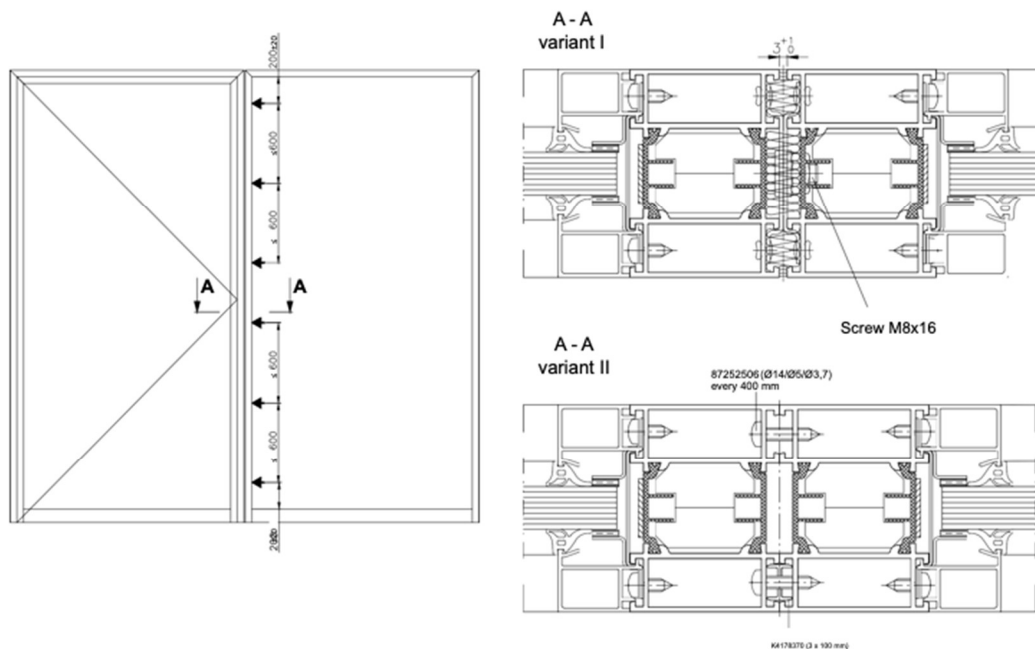

Fig. 20 Screwed connection of fire-rated door system segments (applies to EI30 and EI60 fire resistance classes).

5.2. Installation of ALUPROF MB-78 EI fire doors and technical windows in lightweight framed flexible partition walls clad with plasterboards

Fire doors, technical windows or door assemblies rated EI30 and EI60 may be installed in lightweight framed partition walls clad with plasterboards. Fire constructions rated EI90 must not be installed in flexible walls.

- load-bearing system of a flexible wall should be made from steel U75 and C75 profiles clad on both sides with 15 mm thick fire-rated plaster board,
- for door frames and technical windows installed in framed partition walls, e.g. made of steel profiles with mineral wool core and clad with fire-resistant plasterboards, described in section 4.1 A and B, check the structure of the wall, the type of materials and the minimum wall thickness.
- Examples of the framed partition wall constructions and of how to attach door or fire wall to them are shown in Fig. 12, minimum wall thickness is 105 mm,

MB -78EI Fire-rated doors and technical windows installation guide

- fire door and technical windows frames or the door system frame should be attached to the flexible framed walls with bolts or steel screws (minimum \varnothing 5 mm or M 5), spaced at no more than 600 mm; their distance from frame corners cannot exceed 250 mm, in accordance with Fig. 16,
- the gap between the reveal and the door frame or door system frame must be sealed as described in section 5.2 and shown in Fig. 21

MB -78EI Fire-rated doors and technical windows installation guide

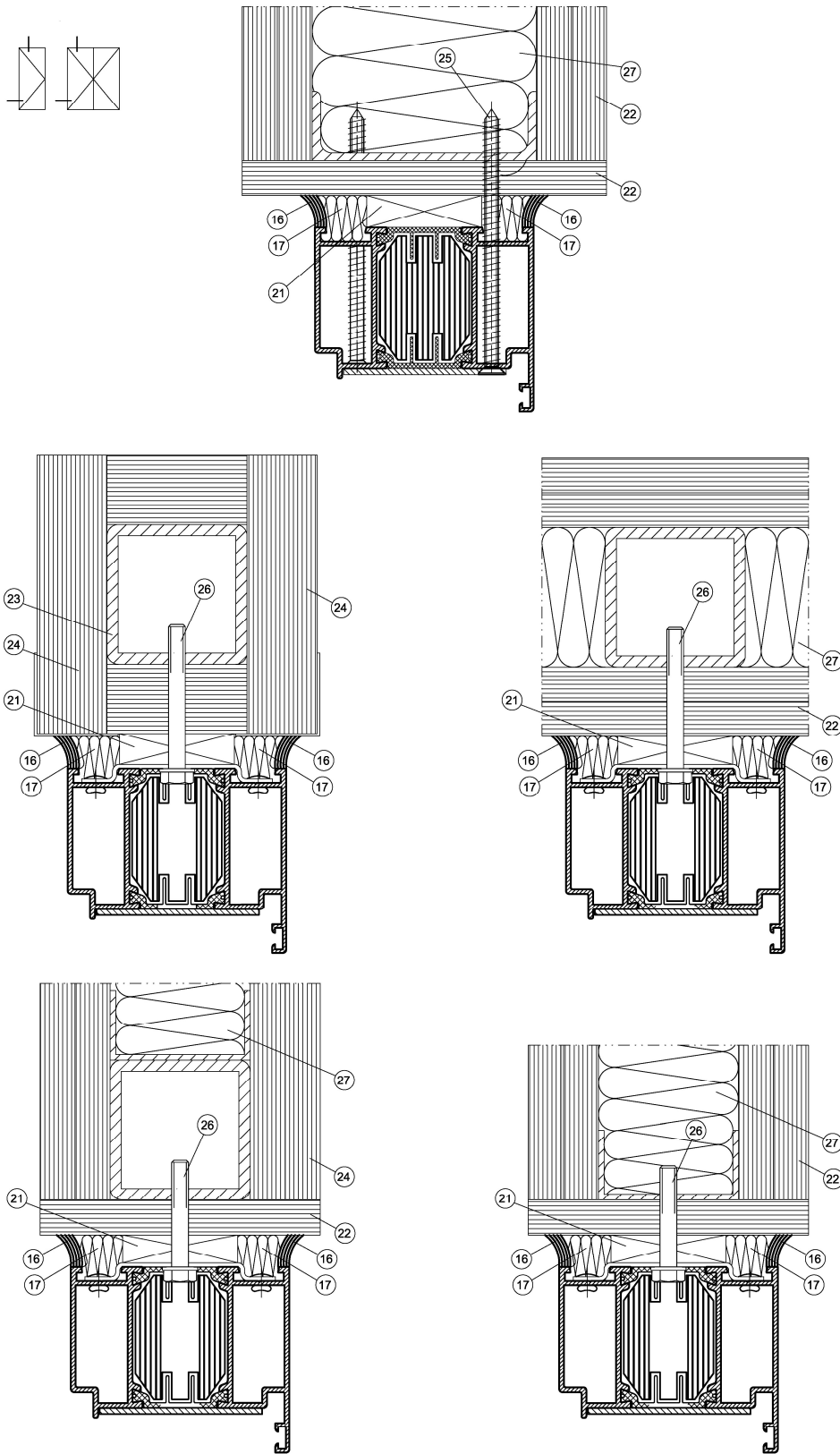

Fig. 21 Sealing variants for frame connections in doors, technical windows and door system frames rated EI30, embedded in framed flexible walls cladded with plasterboards

5.3. Installation of ALUPROF MB-78EI fire doors and technical windows in ALUPROF MB-78EI system fire walls

MB -78EI Fire-rated doors and technical windows installation guide

The guidance below refers to fire doors, door assemblies and technical windows rated EI30 and EI60 embedded in Aluprof MB-78EI system walls. Installation of fire doors and technical windows rated EI90 in Aluprof MB-78EI system walls is not permitted.

In many cases, door assemblies including construction with top/side light and Aluprof MB-78 EI system walls cannot be delivered fully assembled to the site due to their significant size (and thus the inability to be transported by road) or due to the too narrow or too low transport paths that lead to the place of installation. In such cases, structural elements of the door system and building wall should be prepared in the production facility in such a way that the assembly of the framework on the construction site is limited to:

- making 'L' connections with the use of dowels in the door system frame corners using system-specific connectors, catalogue no. 80124270 ; 80124271; 80124321 or 80124322 as shown in Fig. 22,
- making 'T' connections of door system mullions with door system frames and top/side light frames, using system-specific connectors, catalogue no. 8012211 ÷ or 8012215, as shown in Fig. 23,
- if necessary, reinforcing the elements of the framework with expanding seals and glazing support brackets

It is absolutely essential to comply with the following guidelines:

- door leaves must be fully manufactured, assembled and fitted in the production facility (it is permitted to disassemble the elements of fittings or mechanisms that could be damaged during the transport: pulls, handles, door closers, panic bars, etc.), but the holes for their fixing must be prepared in the production facility),
- elements of mullions, transoms and crosspieces are prepared by the production facility (length, angles of cuts, holes for installation of 'L' and 'T' connection elements),
- each element should be fitted with frame connectors (catalogue no. 80322073) or frame connectors with anchor (catalogue no. 80322086) in sufficient quantities and spaced in accordance with section 4.3.3. and with glazing connector (catalogue no. 80322074 and glazing angles (80322103- 80322109 or 80322124 or 80322128 or 80322159- 80322160) with dimensions adapted to the thickness of the panes, in accordance with Figs. 38, 39, 40,
- twisting of side light elements with the door frame or twisting of wall segments, when supplied as separate frames, shall be in accordance with section 5.1.2 and Fig.20,
- when making 'L' connections, the installer shall:

- fill the 'L' connectors' chamber with firestop sealant, catalogue no. 14614959 up to about 1/3 of their volume,

- cover the surface of the 'L' connectors with glue, catalogue no. 13364612 ,

MB -78EI Fire-rated doors and technical windows installation guide

- place insulation inserts made of materials appropriate for given fire resistance class and of appropriate angle and length in the respective chambers, according to Table 2 and Fig. 22,
- pin the connection with dowels, catalogue no. 80376014,
- remove excess glue and clean the connection.

Connections are to be made in accordance with Fig. 22.

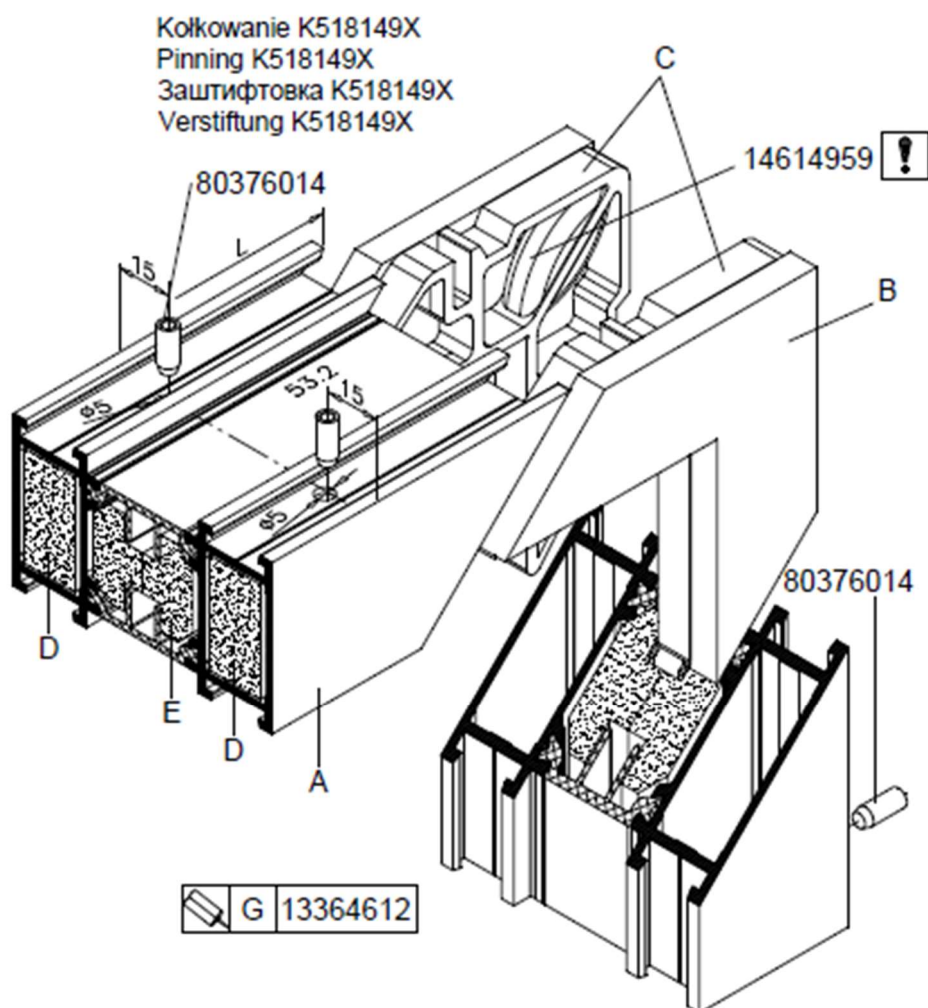

Fig. 22 'L' connections for circumferential door system frames

MB -78EI Fire-rated doors and technical windows installation guide

Table 2 shows the principle of selecting elements to create 'L' connections for door frames or circumferential door system frames with the use of dowels, according to the length of fire insulators' cut

(L – length of frame profile or frame)

Table 2

A	B	C	D		E	
profile	Insulator of the connector	'L' connector	Outer chambers insulator	Length of cut	Middle chamber insulator	Length of cut
FIRE RESISTANCE CLASS EI 30 (GKF inserts)						
K518142X	80462126	80124271			80462115 + 80462114	L-12 L-8
K518143X	80462108	80124270			80462112	L-10
K518149X	80462127	80124322			80462177	L-10
K518395X	80462179	80124270			80462111	L-5
K518138X	80462108	80124321			80462111	L-5
FIRE RESISTANCE CLASS EI 30 (CI inserts)						
K518142X	80462126	80124271			80462182	L-8
K518143X	80462108	80124270			80462183	L-10
K518149X	80462127	80124322			80462193	L-10
K518395X	80462179	80124270			80462187	L-5
K518138X	80462108	80124321			80462187	L-10
FIRE RESISTANCE CLASS EI 60 (GKF inserts)						
K518142X	80462126	80124271	80462113	L-75	80462115 + 80462114	L-12 L-8
K518143X	80462108	80124270	80462109	L-75	80462112	L-10
K518149X	80462127	80124322	80462178	L-75	80462177	L-10
K518395X	80462179	80124270	80462110	L-75	80462111	L-5
K518138X	80462108	80124321	80462120	L-75	80462111	L-5
FIRE RESISTANCE CLASS EI 60 (CI inserts)						
K518142X	80462126	80124271			80462181 + 80462182	L-12 L-8
K518143X	80462108	80124270			80462184	L-10

MB -78EI Fire-rated doors and technical windows installation guide

K518149X	80462127	80124322			80462189	L-10
K518395X	80462179	80124270			80462188	L-5
K518138X	80462108	80124321			80462188	L-10
FIRE RESISTANCE CLASS (CI inserts)						
K518142X	80462126	80124271	80462180	L-75	80462181 + 80462182	L-12 L-8
K518143X	80462108	80124270	80462186	L-75	80462184	L-10
K518149X	80462127	80124322	80462195	L-75	80462189	L-10
K518395X	80462179	80124270	80462190	L-75	80462188	L-5
K518138X	80462108	80124321	80462186	L-75	80462188	L-10

- when making 'T' connections, the installer shall:
 - check the spacing of the connectors and the fixing or correct the spacing and fix the 'T' connectors,
 - fill the 'T' connectors' chamber with firestop sealant, catalogue no. 14614959 up to about 1/3 of their volume,
 - cover the surface of the 'T' connectors with glue, catalogue no. 13364612 ,
 - place insulation inserts made of materials appropriate for given fire resistance class and of appropriate length in the respective chambers, in accordance with Fig.2
 - pin the connection with dowels, catalogue no. 80376015,
 - remove excess glue and clean the connection.

Connections are to be made in accordance with Fig. 23.

MB -78EI Fire-rated doors and technical windows installation guide

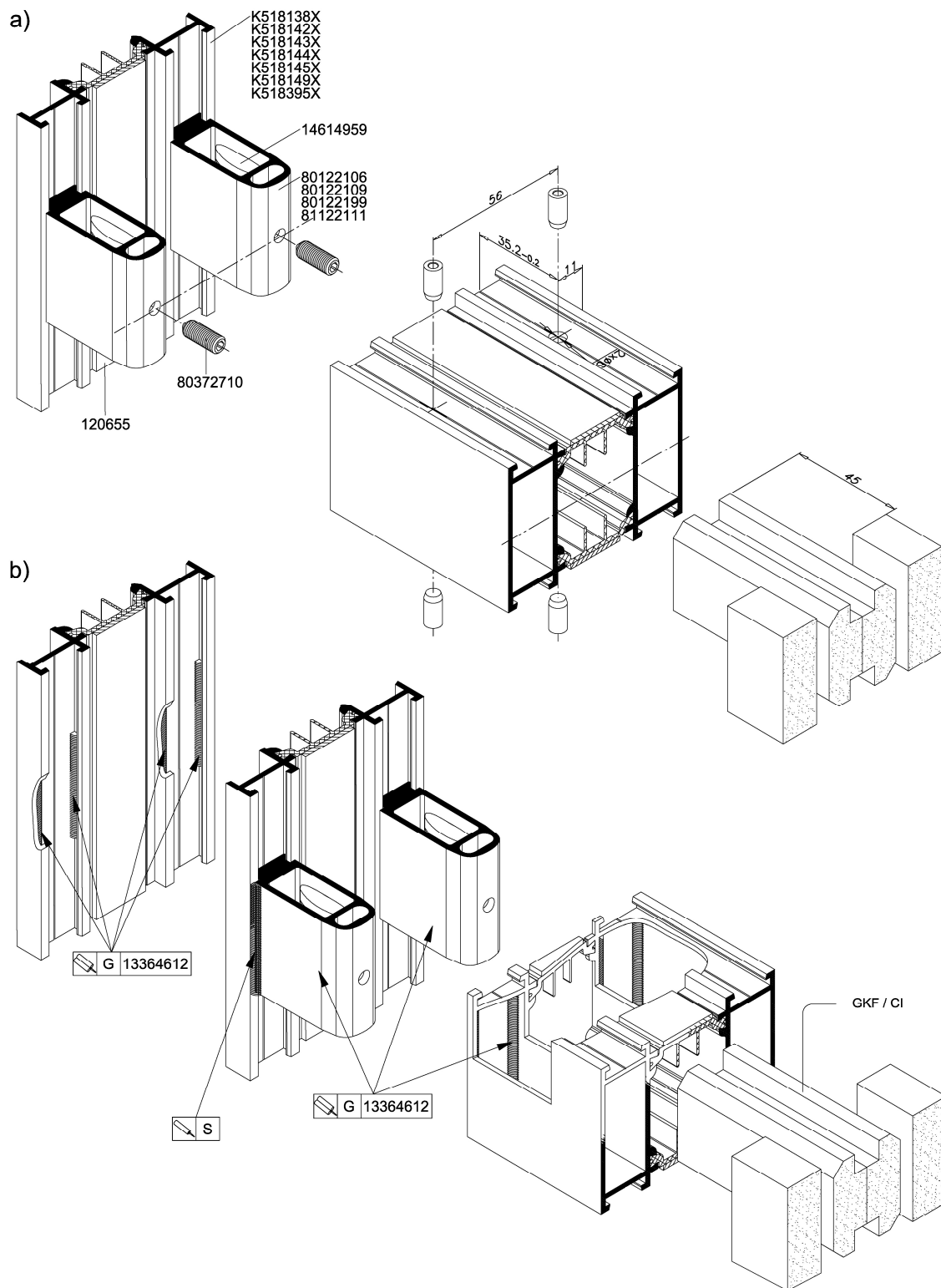

Fig. 23 'T' connections of transoms, crosspieces and mullions
a) use of fasteners,
b) sealing with firestop sealants and glues

MB -78EI Fire-rated doors and technical windows installation guide

- further installation works in the building aperture shall be carried out in accordance with section 5; 5.1.2.
- depending on the results of static calculations, fire resistance classes and wall heights, it is necessary to stiffen the frame mullions with a reinforcement profile K 413923 X + K 413923 X over the entire wall height, as shown in Fig. 24 and Table 3.

Table 3.

Principles and requirements for stiffening of fire wall mullions and door system mullions

Fire resistance class	Wall height [mm]	Max. screw spacing X [mm]	Stiffening and conditions for application		
			Single	Double	with additional steel profile
EI 30	to 3599	400	No (unless static calculations indicate otherwise)	No (unless static calculations indicate otherwise)	
	3600 - 4800	300	always	Unless static calculations indicate otherwise	Unless static calculations indicate otherwise
EI 60 EI 90	to 3399	400	No (unless static calculations indicate otherwise)	No (unless static calculations indicate otherwise)	
	3400 - 4000	400	always	Unless static calculations indicate otherwise	Unless static calculations indicate otherwise
	4001 - 5160	250	always	Unless static calculations indicate otherwise	Unless static calculations indicate otherwise

MB -78EI Fire-rated doors and technical windows installation guide

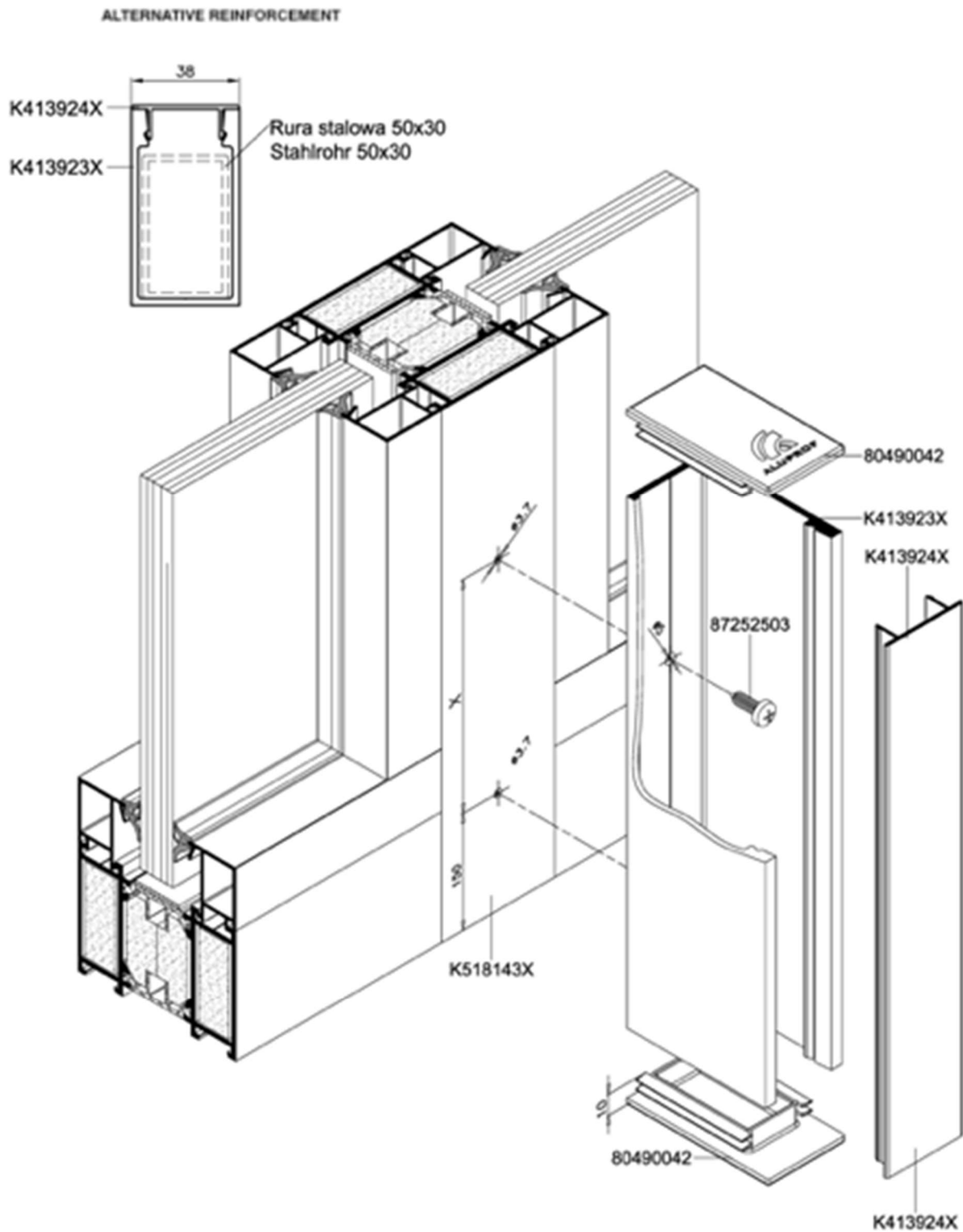

Fig. 24 Installation door system or fire wall mullion stiffening

5.4. Installation of fire doors and technical windows in ALUPROF MB – SR50N EI curtain walls

Guidance on integration of fire doors, door assemblies and technical windows rated EI 30 and EI60 in ALUPROF MB-SR50N EI filling type curtain walls is described in a separate manual.

Installation of fire doors and technical windows rated EI90 in ALUPROF MB-SR50N EI90 curtain walls is not permitted.

Door or technical window frame should be embedded in the curtain wall construction in accordance with Fig. 25 and description in section 4.2.3.

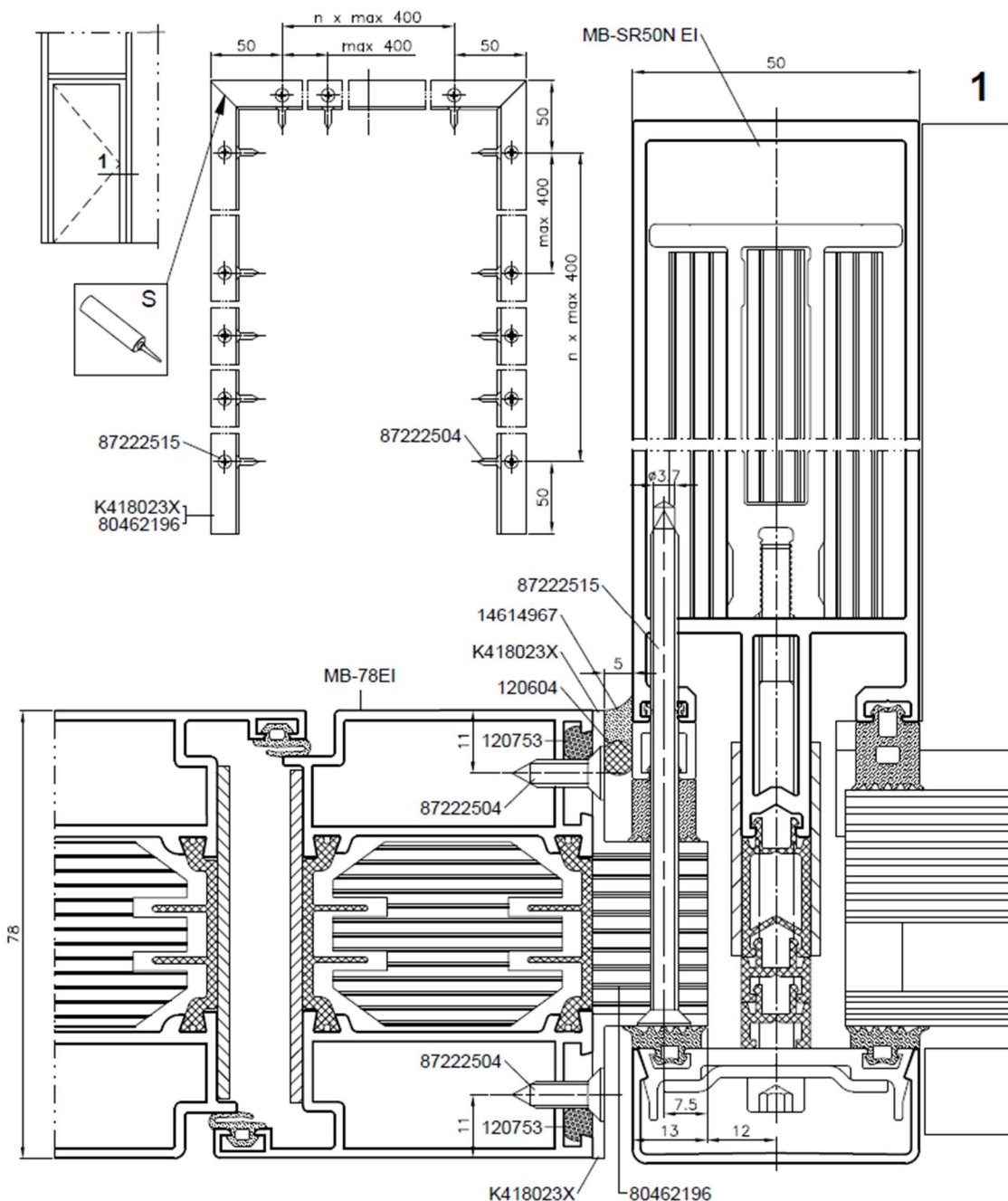

Fig. 25 Installation of door frame in ALUPROF MB-SR50N EI filling type curtain wall

5.5. Clearances

5.5.1. Clearance between door leaf and floor

The maximum permissible clearance between the door leaf in closed position and the floor should be maintained over the entire width of the leaf (leaves).

In order to prevent the leaf from rubbing against the floor, the floor finish must be made taking into account the direction of door opening indicated in the basic design of the building, so that the maximum permissible clearance specified in Fig. 26 is maintained.

The floor shall be constructed and levelled in such a way that the maximum difference between the lowest point of the floor under closed leaves (Fig. 25 - Field 1) and the highest point under open doors (Figure 25 - Field 2) does not exceed the maximum permissible clearance, less 2 mm.

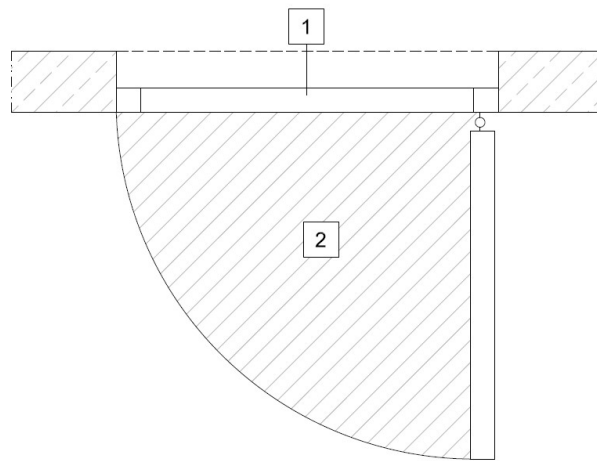

Fig. 26 Checking the levelling of the floor

Below, Fig. 27 shows the permissible clearance between the leaf and the floor for different variants of door stop sealing

MB -78EI Fire-rated doors and technical windows installation guide

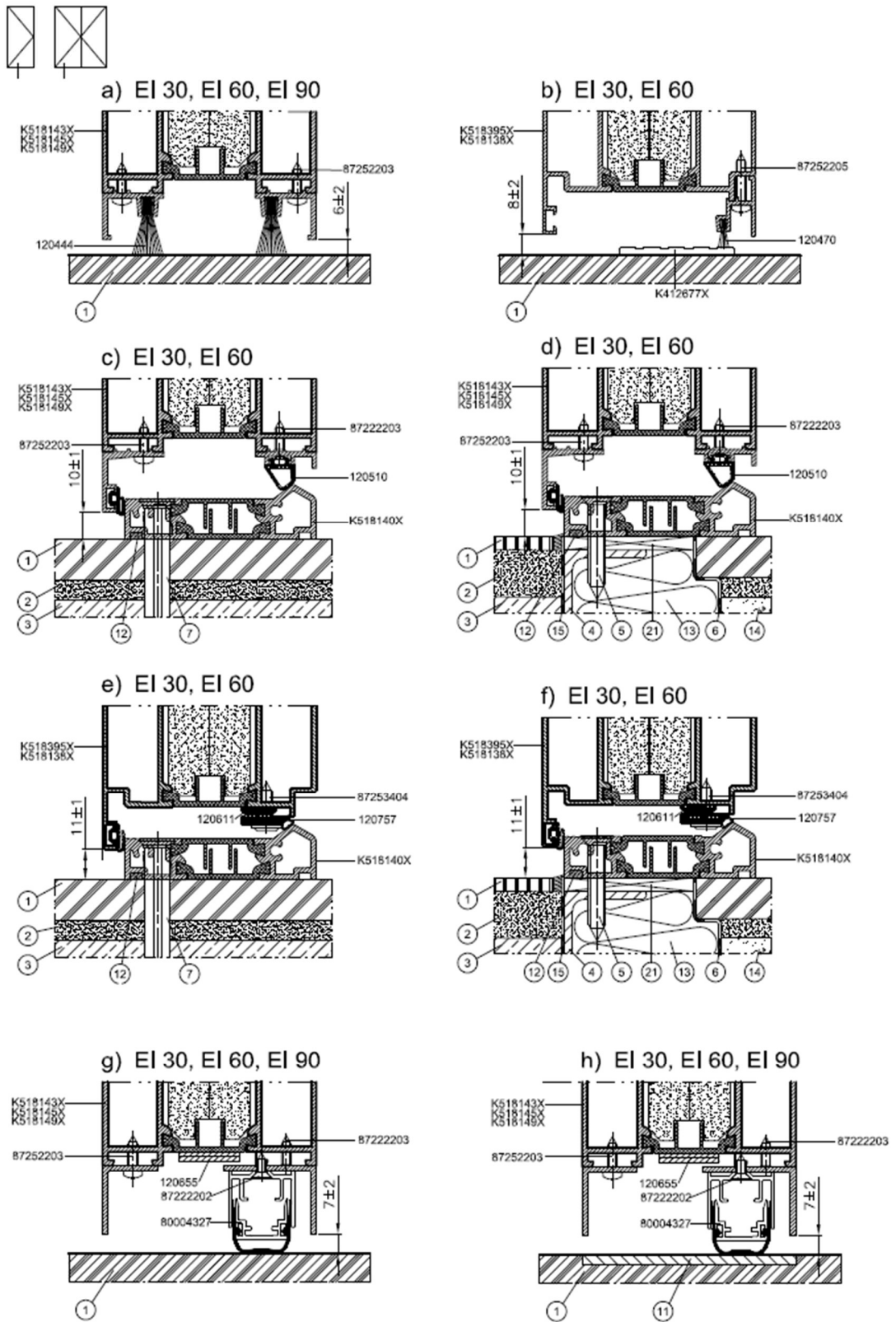

Fig. 27 Variants of door stop sealing – clearance between floor and leaf (applies to all fire resistance classes)

5.5.2. Clearance between frame and reveal

Door frames can be made as three-element products (2 door posts and 1 upper transom) with door threshold made of the K518140X profile or without threshold. In technical windows all four elements of the frame (2 door posts and 2 lower and upper transoms) are made of the same profile.

In the case of each frame type, the “Z” clearance between the reveal and the upper transom depends on the door or technical window fire resistance class. According to Fig. 1d – in the case of fire constructions rated EI30 and EI60, the clearance is 20 to 25 mm, and in the case of constructions rated EI90, the clearance is 15-20 mm.

5.5.3. Clearance of the base connection technical windows or side panels of MB-78EI door systems

In the case of technical windows or side panels (side light) the base connection clearance should be:

- 3 – 5 mm – according to Fig. 28 a - when window or wall frame profile is fixed to the floor by means of element 80322073,
- 0 mm – according to Fig. 27 b – when the profile is fixed to the floor by means of steel concrete screws,
- for doors with threshold profile K 518140x, the clearance between the floor and the threshold should not exceed 2 mm in accordance with Fig. 28 c and d.

The size of clearance between floor surface and door leaf depends on how the lower door stop is profiled in the case of doors with or without threshold – clearances in doors are shown in Fig. 27.

MB -78EI Fire-rated doors and technical windows installation guide

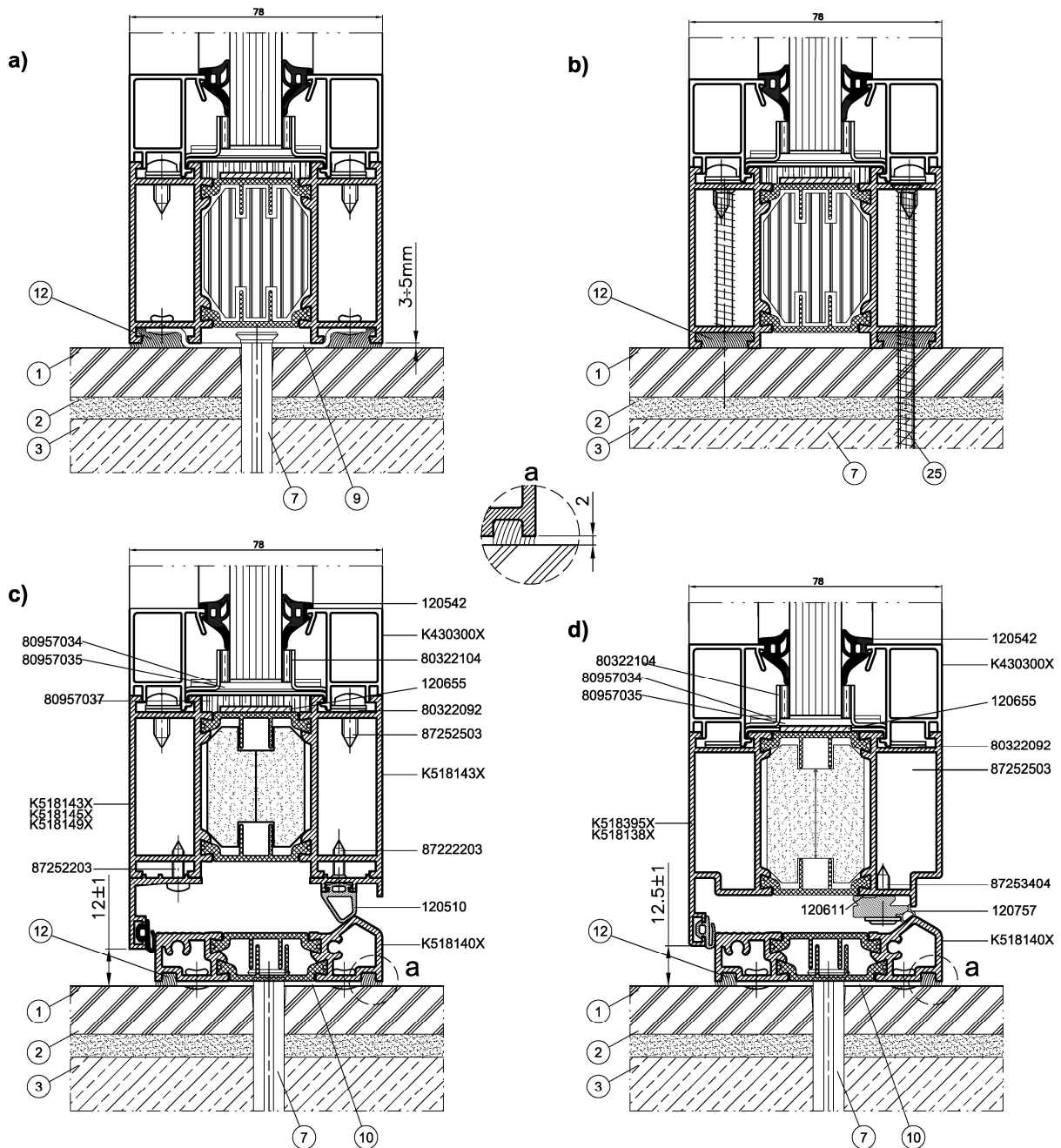

Fig. 28 Clearances of base connection when installing:
a, b) technical window or side light wall frame (for all fire resistance classes)
c, d) door threshold (EI30 and EI60 resistance class)

MB -78EI Fire-rated doors and technical windows installation guide

5.5.4. Perimeter clearances between leaf and door frame and between leaves

In accordance with ALUPROF technical documentation, Figs. 29, 30 and Table 4, the maximum permitted clearances are:

Table 4

Maximum permissible clearances in fire door constructions

Maximum permissible clearances in doors		
Clearance-measuring location	with standard devices	with emergency exit and panic door devices
Between door leaf and frame – upper assembly	5 ± 1 mm	5 ± 1 mm
Between door leaf and frame (line with hinges)	5 ± 1 mm	5 ± 1 mm
Between door leaf and frame (line with lock)	5 ± 1 mm	$(5 \text{ or } 6 \text{ mm})^* \pm 1$ mm
Between double door leaves	5 ± 1 mm	$(5 \text{ or } 7 \text{ mm})^* \pm 1$ mm
Between door leaf and floor	In accordance with section 5.5.1 and Fig. 16	In accordance with section 5.5.1 and Fig. 16

* in accordance with document 14-001124-PR01 PB-C01-03 de-03 – ability to release

MB -78EI Fire-rated doors and technical windows installation guide

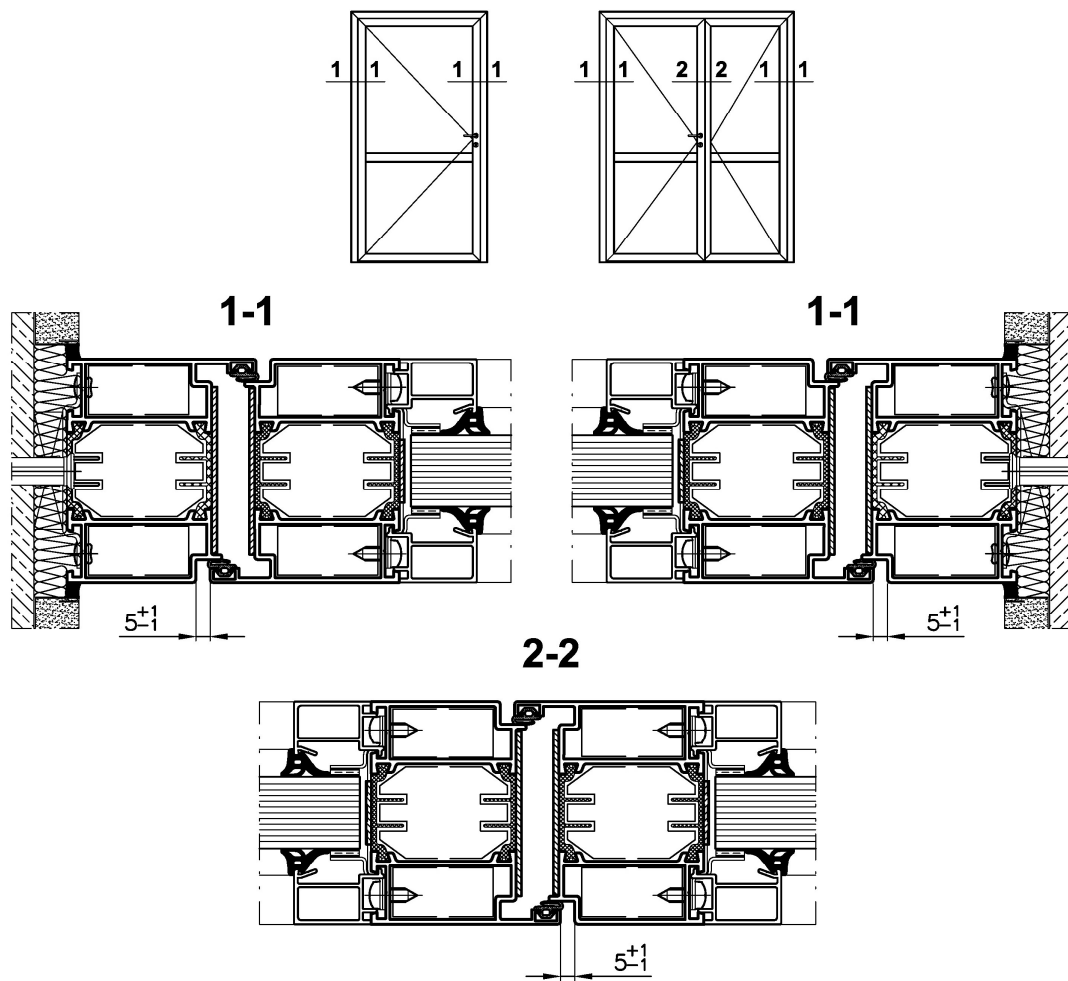
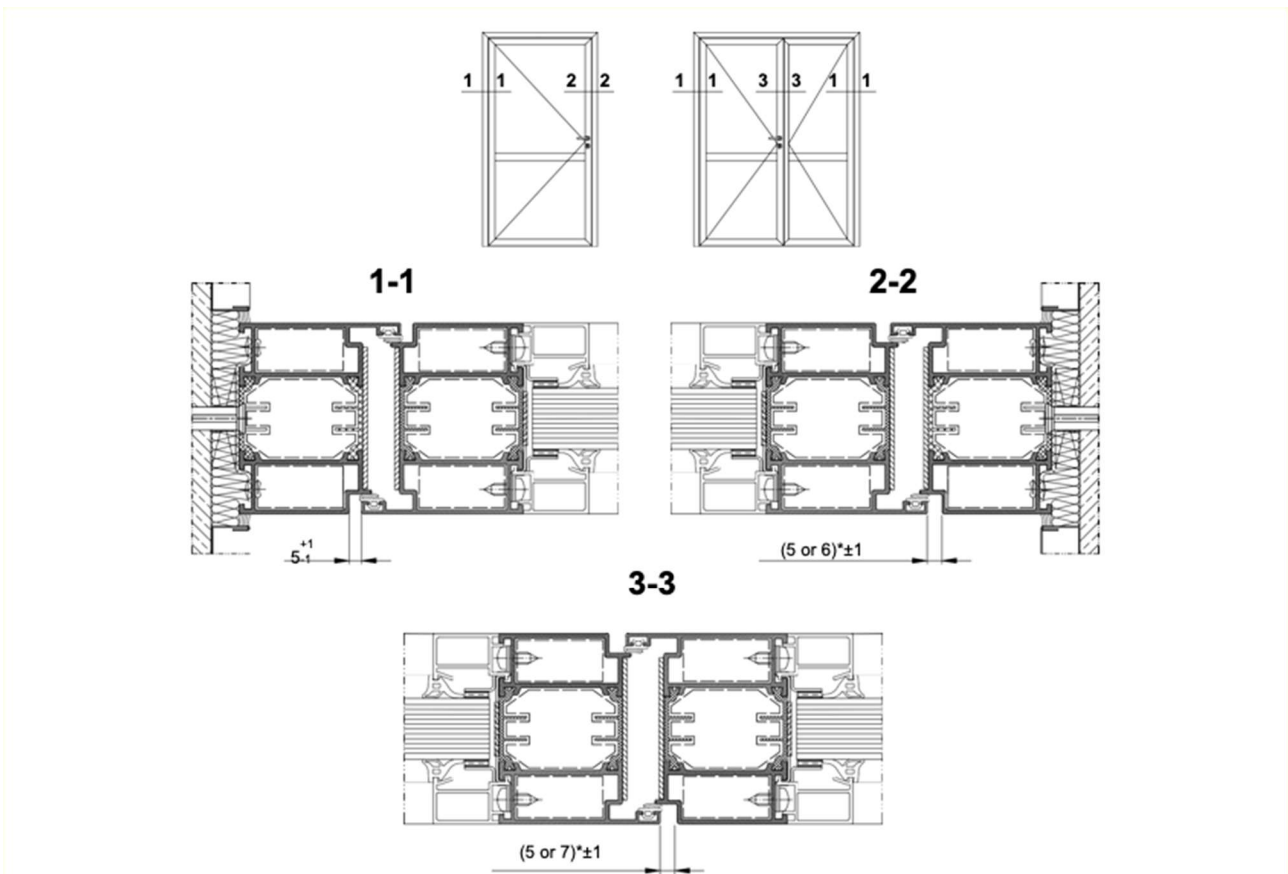

Fig. 29 Doors with standard closing devices – permissible clearances between frame and leaf, and between leaves



- in accordance with document 14-001124- PR01-C01-03-de-03 – “Ability to release”

Fig. 30 Doors with standard emergency exit and panic devices – permissible clearance between frame and leaf, and between leaves

6. Installation of complementary elements of doors and frames

If doors or walls are delivered in elements due to their large size or, for example, due to narrow and low transport paths, it is necessary to assemble them on the construction site. This applies to the following additional steps and installation operations listed in sections 6.1 to 6.4.2.

6.1. Working of upper and side door stops

For single and double doors with top/side light, it is necessary to work upper and side door stops in the frame passage opening of side and upper stops using the K 518139X strip.

Fig. 31 shows how to prepare the strip for installation and the maximum distance between the screws that fix the strip to the mullions and transoms of the construction.

In general, the strip is prepared in the production facility, however, if there are no fixing holes or if there is a need to provide additional restraint to the edging strip, the spacing and diameters of the holes given in Fig. 31 should be maintained. After fixing the strip, apply swelling tape 120656 to its surface.

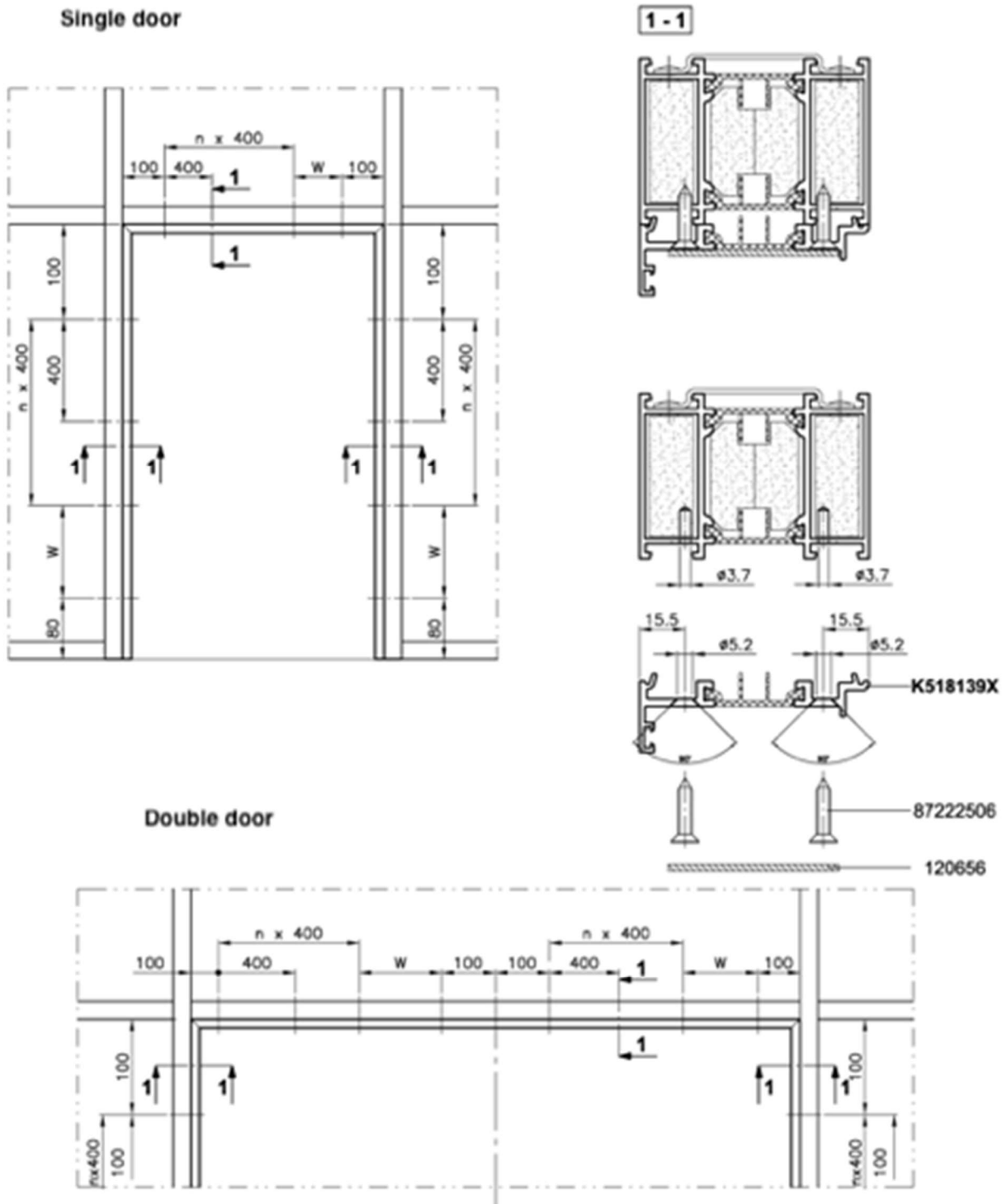

Fig. 31 Installation of edging strip K518139X

6.2. Door stop sealing for doors with threshold

Fig. 32 shows how to prepare the threshold profile K 518140X and its embedding between door jambs that meet the smoke-control requirement. After attachment to the frame, the threshold should be fixed to the floor with steel anchors or concrete screws as shown in Fig. 28.

MB -78EI Fire-rated doors and technical windows installation guide

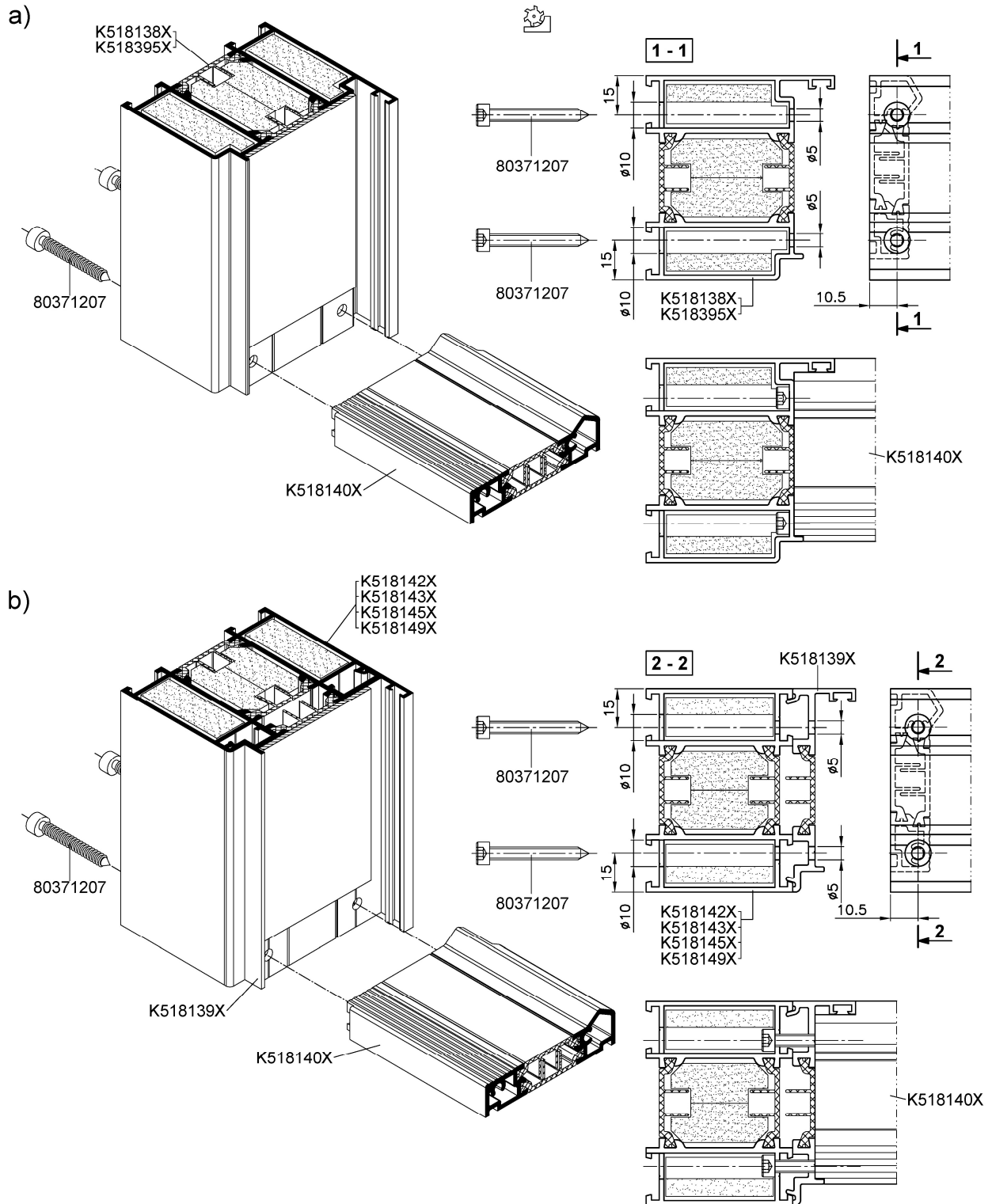

Fig. 32 Threshold installation for EI 30 and EI 60 doors:

- a) in monolithic clear opening of profiles K 518138 X or K518395X,**
- b) in clear opening consisting of mullion profile and edging strip K 518139X**

6.3. Door stop sealing in smoke control door frames

At the bottom corners of door frames with a threshold or automatic sealing strip, a sealing plate with brush seals (catalogue no. 80111320 or 80111350) must be fitted in the locations, and as shown in:

- Fig. 32a - when the door stop sealing is made with threshold profile K518149 x and gasket 120 519 or 120 757,
- Fig. 33b - when the sealing of the lower door stop is made with automatic sealing strip

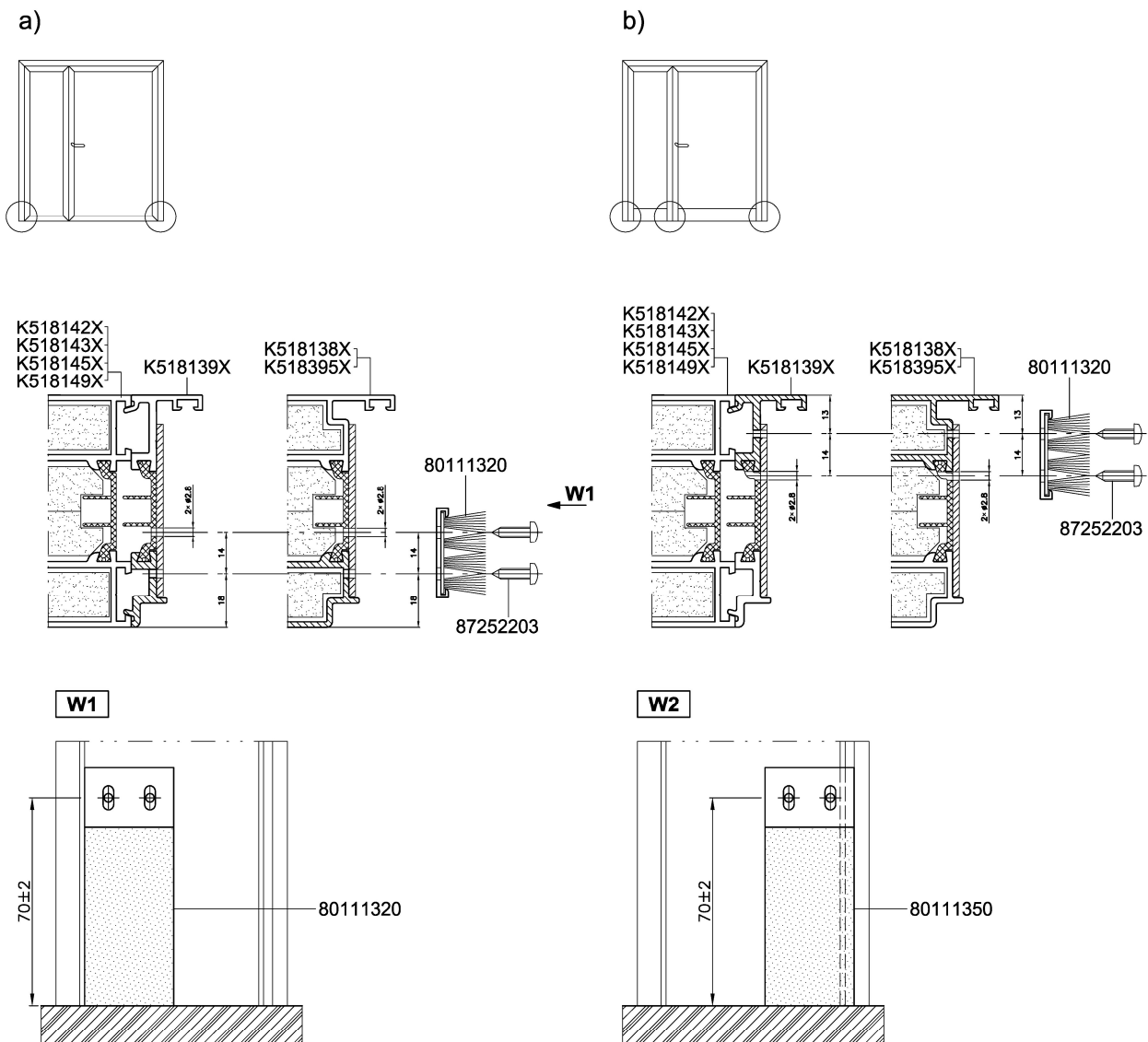

Fig. 33 Door stop sealing (applies to all fire resistance classes):

- a) door with threshold,
- b) door with automatic sealing strip

6.4. Door leaf – sealing of lower corners

6.4.1. Sealing of corners of the inactive leaf made of profiles K 518138X or K518395X

MB -78EI Fire-rated doors and technical windows installation guide

Fig. 34 shows how to install lower corner sealing for the inactive leaf made of profiles K 518138X

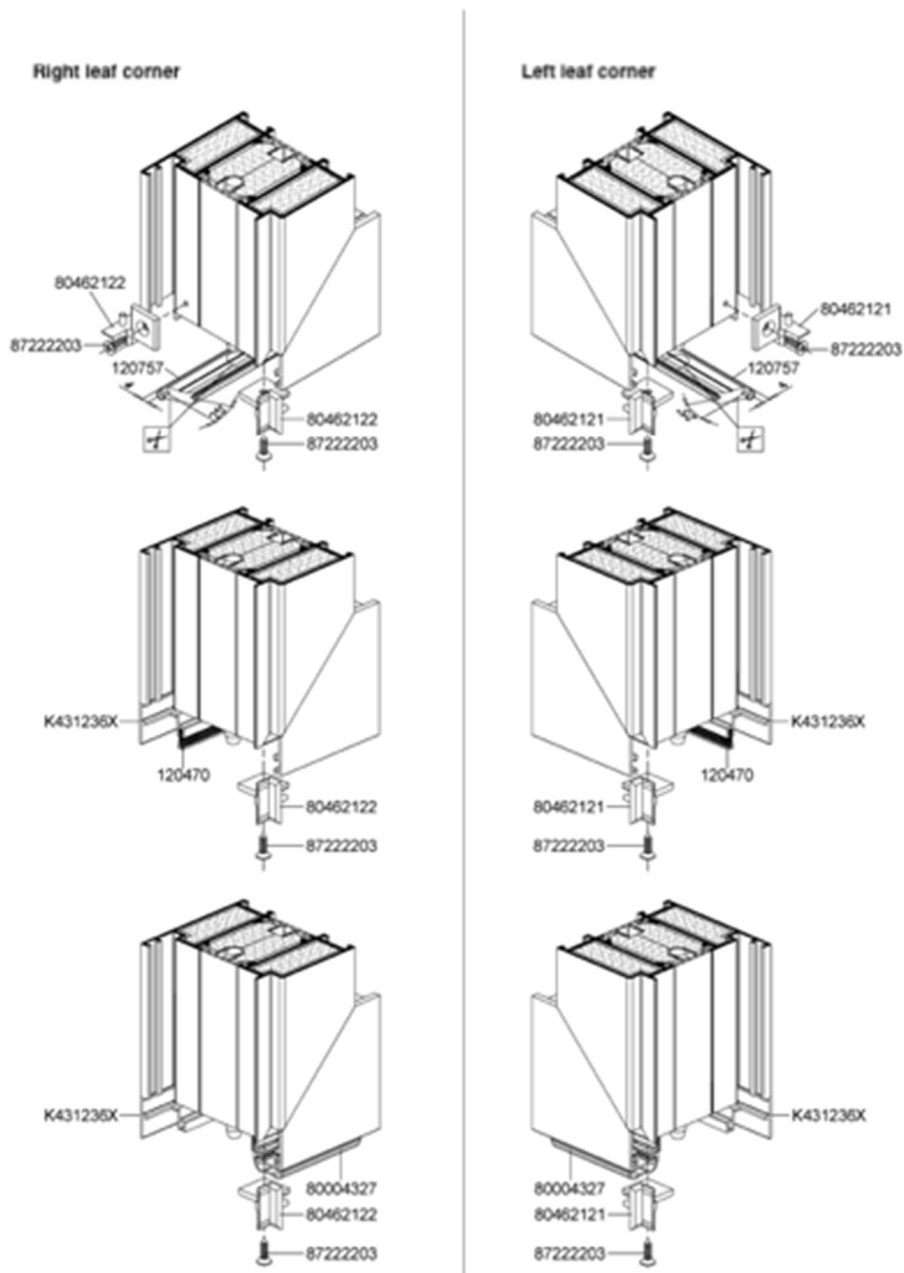

or K518395X.

Fig. 34 Sealing of lower corners of the inactive leaf (made of profiles K518138X or K518395X around the entire perimeter of the leaf frame)

6.4.2. Sealing of leaf corners made of crosspiece profiles

MB -78EI Fire-rated doors and technical windows installation guide

Figures 35 and 36 show corner sealing in single and double doors, in which the lower crosspiece of the leaf is made of profiles: K 5118142X or K 5118143X, or K 5118145X, or K 5118149X.

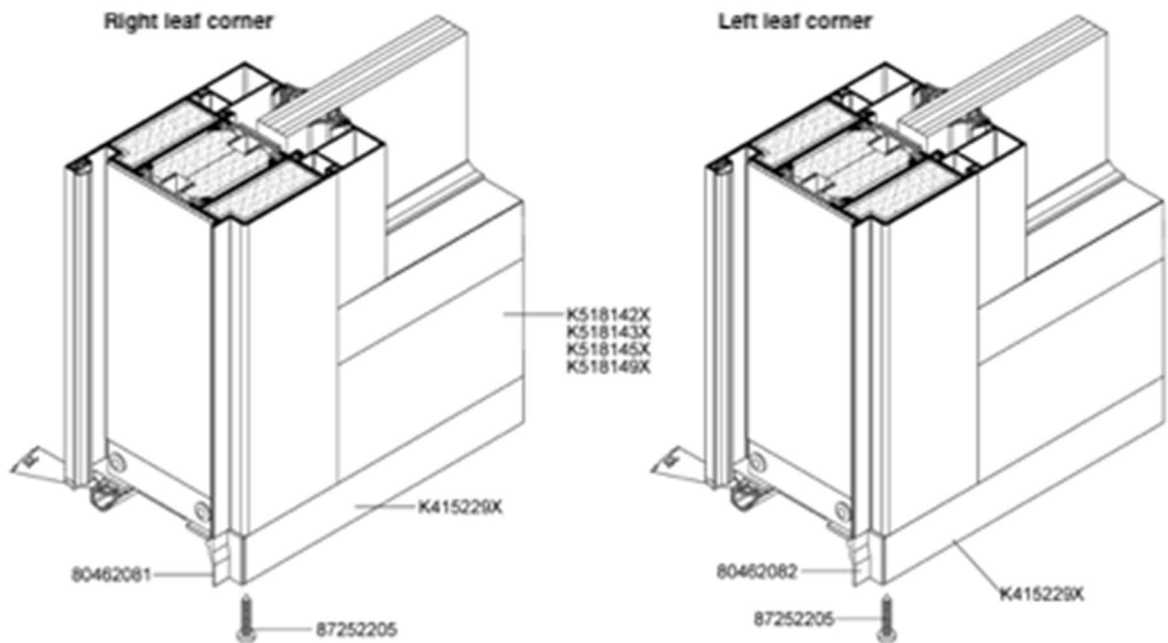

Fig. 35 Sealing of lower corners of the inactive leaf (leaf frame lower transom made of crosspiece profile)

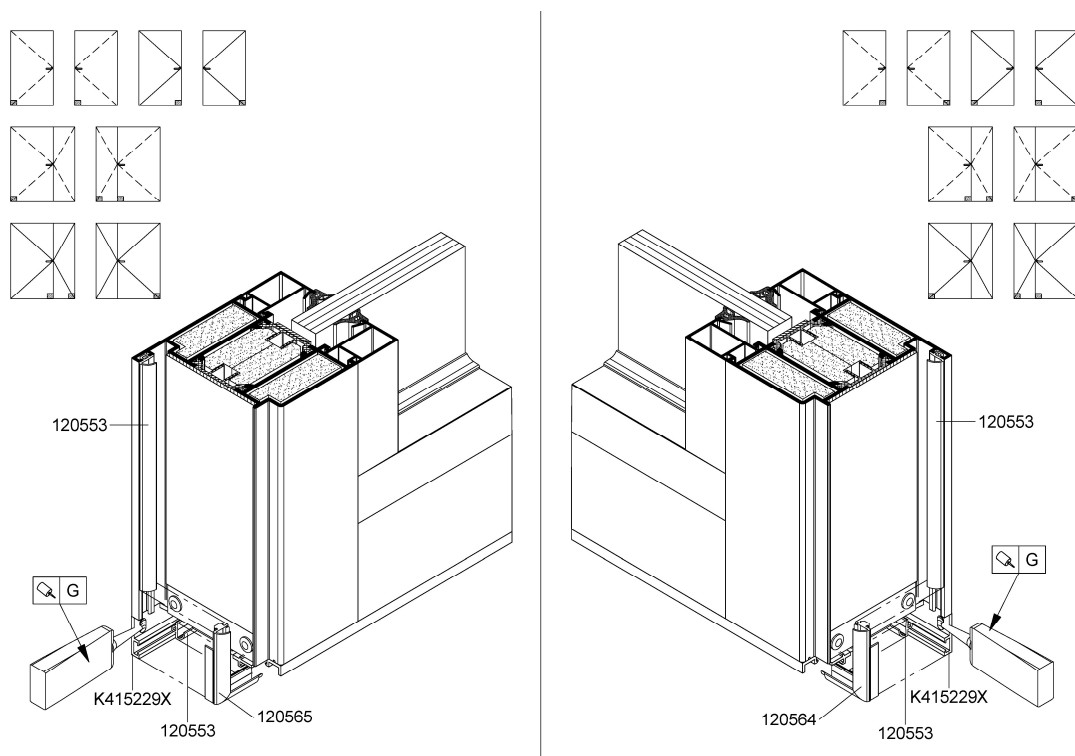

Fig. 36 Sealing of lower corners of the active and inactive leaf (leaf frame lower transom made of crosspiece profile)

6.5. Arrangement of door hinges

Figure 37 shows the arrangement of door hinges – this diagram is valid for all fire resistance classes in doors. The quantity of hinges and their correct positioning is the responsibility of the door manufacturer – the installer should check these dimensions after the door has been embedded.

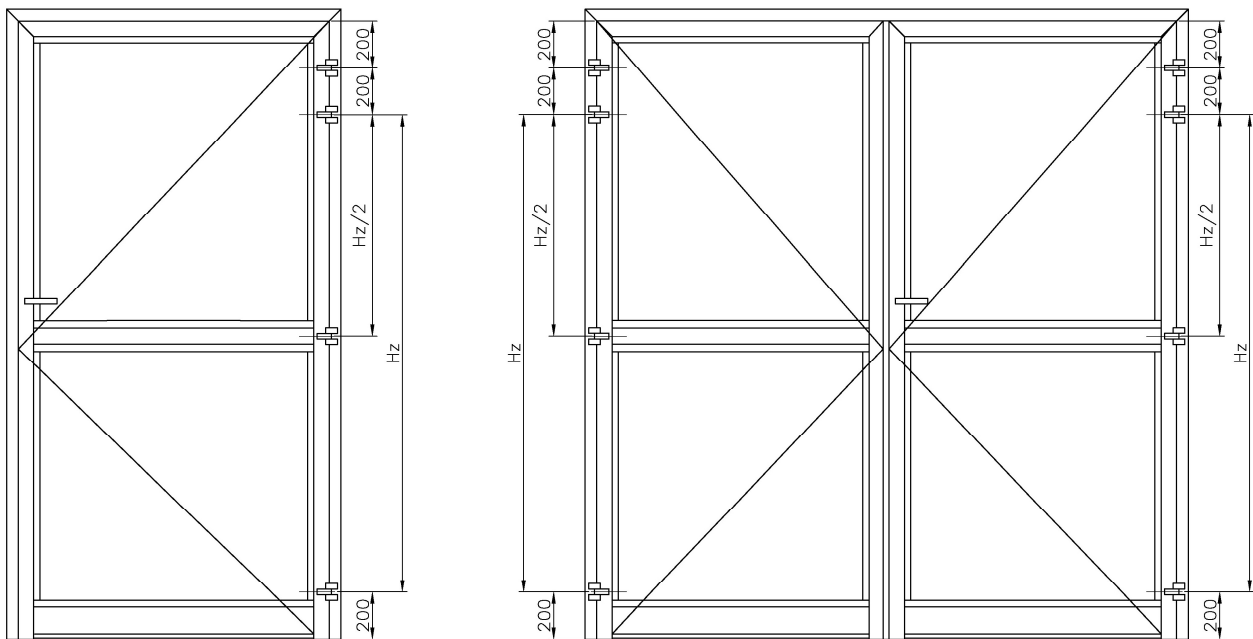

Fig. 37 Arrangement of hinges

7. Glazing

7.1. Determination of the nominal thickness of fire-resistant glass

Fire-resistant single-glazed and sealed insulating glass panes are characterized by significant deviations in thickness. Deviations in thickness depend on the actual (nominal) thickness of the glass. The thicker the glass and the higher the fire resistance class of the glass, the greater the tolerance of its actual dimension. The average deviation is within the following limits:

± 1 mm for glass with a fire resistance of 15; 20 and 30 min.

± 2 mm for glass with a fire resistance of 60 min.

Individual glass formats from the same production batch with the same nominal size may in fact have the outermost thickness dimensions resulting from the above tolerance field. Significant differences in thickness may also occur within 1 glass format when measuring along the edge of the glass. Practice shows that the manufacturer, when prefabricating the door, prepares the

MB -78EI Fire-rated doors and technical windows installation guide

construction for the installation of glass of nominal thickness, while the glass delivered directly to the construction site may have a different actual thickness.

Therefore, prior to the commencement of glazing, the installer should determine the actual, average thickness of each glass pane to be installed by measuring it.

Measure with a calliper with a measurement accuracy of 0.01 mm:

- the thickness at 4 corners of the glass,
- the thickness along each edge of the glazing, as follows:
 - for edges of glass of up to 1.2 m in the middle of its length,
 - for edges of glass of up to 1.8 m every 1/3 of the edge length,
 - for edge above 1.8 m every 1/4 of the edge length.
- calculate the arithmetic mean of the measurements carried out.

7.2. Selection of glazing elements

Figures 38, 39 and 40 show arrangement of steel angles that fix the glass panes according to thickness of the fire-rated glass and fire resistance class. The maximum distance between internal corner of the leaf frame or side or upper panel should not exceed 150 mm for all fire resistance classes. The maximum 'A' distance between subsequent angles for fire constructions rated EI 30 and EI 60 are 500 mm, and in the case of fire constructions rated EI90, the 'A' distance should not exceed 300 mm. The type and size of angles depends on the thickness of the glass; the selection of angles is shown in Figures 40, 42 and 42. Gaskets shall be selected in accordance with tables shown in Figures 44 or 45 a, b, c. The selection principle shown in Fig. 44 is a standard solution, while the one shown in Fig. 45 a, b, c allows for glazing from inside the construction of fixed windows located on higher floors of the building or, for example, walls on mezzanines without the need to erect scaffolding.

MB -78EI Fire-rated doors and technical windows installation guide

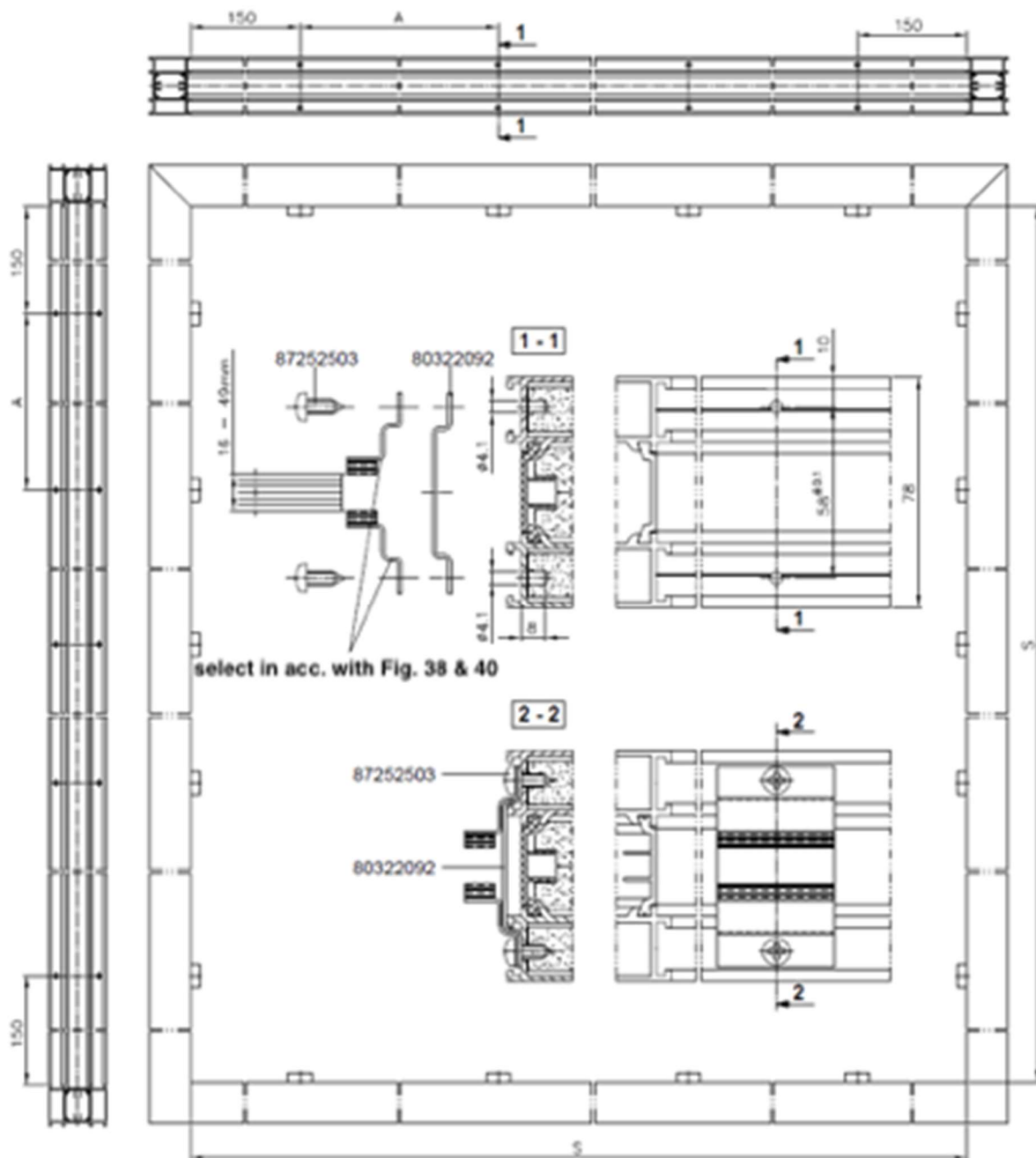

Fire resistance class	Maximum distance between fixing elements A [mm]	Special conditions for installation
EI30	500	In doors ≤ 2500 mm high permissible dimension A on vertical racks and upper bar must not exceed 800 mm, lower bar does not require fixing elements
EI60	500	-
EI90	300	-

MB -78EI Fire-rated doors and technical windows installation guide

Fig. 38 Dimensional relationships of the arrangement of glass-fixing elements in the leaf frame or in the wall frame for 16 - 49-mm-thick panes

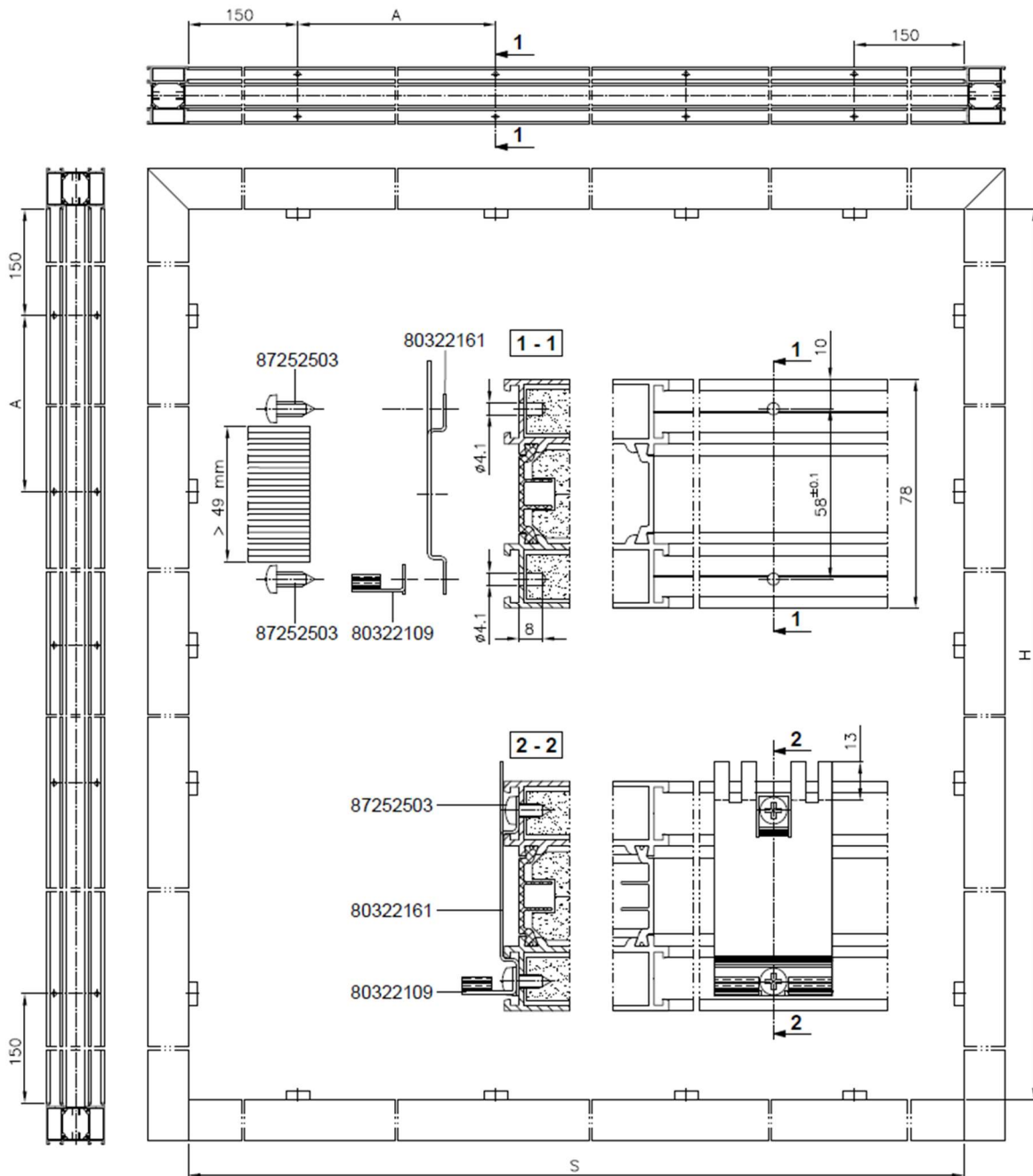

Fire resistance class	Maximum distance between fixing elements A [mm]	Special conditions for installation
EI30	500	In doors ≤ 2500 mm high permissible dimension A on vertical racks and upper bar must not exceed 800 mm, lower bar does not require fixing elements

MB -78EI Fire-rated doors and technical windows installation guide

EI60	500	-
EI90	300	-

Fig. 39 Dimensional relationships of the arrangement of glass-fixing elements in the leaf frame or in the wall frame for 49 - 60-mm-thick panes

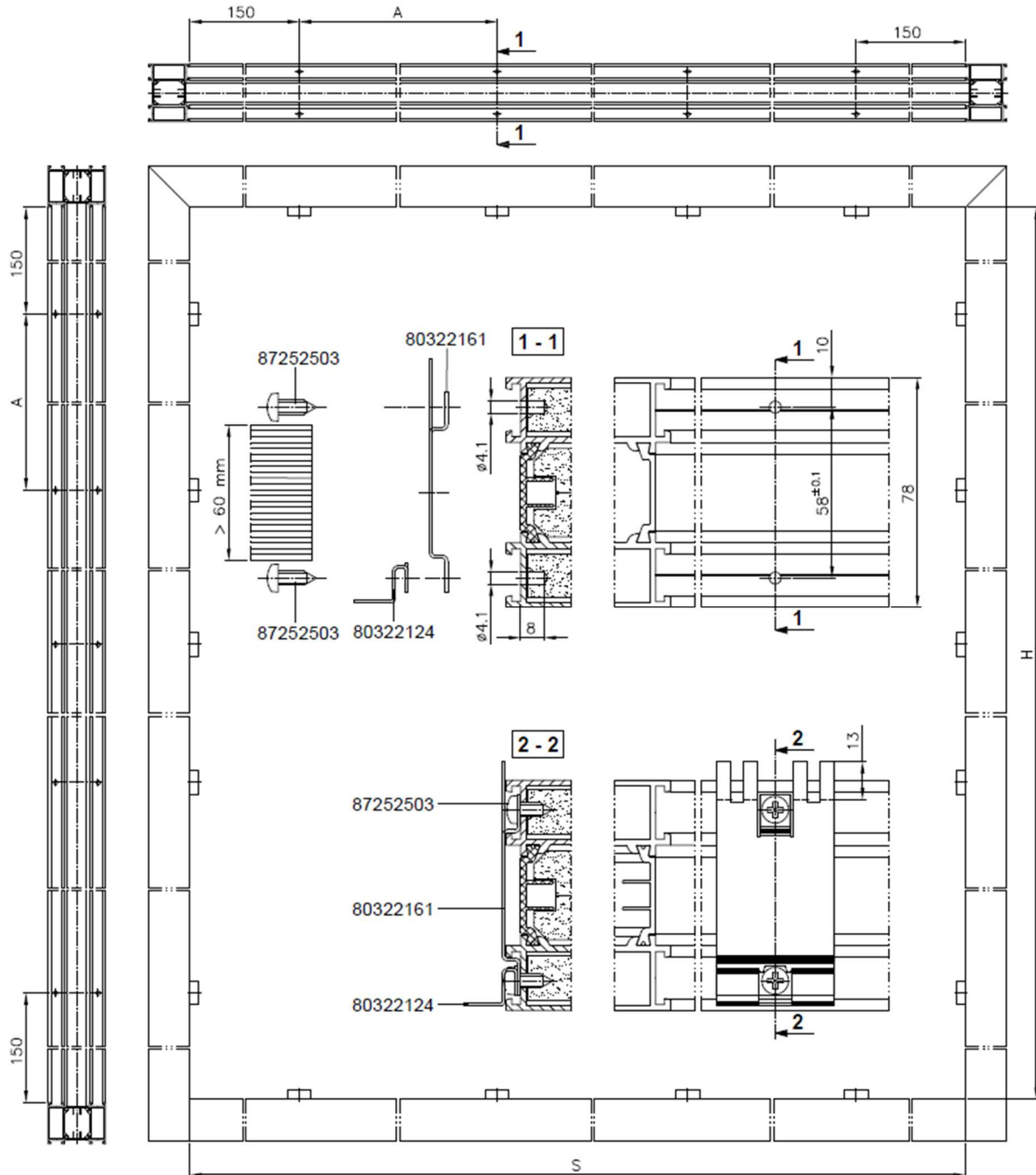

Fire resistance class	Maximum distance between fixing elements A [mm]	Special conditions for installation
EI60	500	-
EI90	300	-

MB -78EI Fire-rated doors and technical windows installation guide

EI30	500	In doors ≤ 2500 mm high permissible dimension A on vertical racks and upper bar must not exceed 800 mm, lower bar does not require fixing elements
EI60	500	-
EI90	300	-

Fig. 39 Dimensional relationships of the arrangement of glass-fixing elements in the leaf frame or in the wall frame for panes thicker than 60 mm

MB -78EI Fire-rated doors and technical windows installation guide











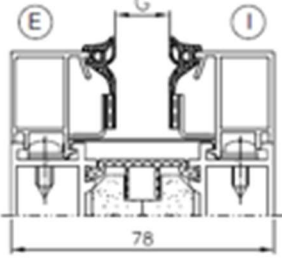

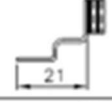
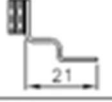
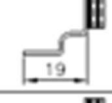
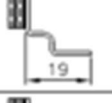







	Glazing angles – full set	
	E	I
16	80322104 	80322104 
$16 < G \leq 20$	80322105 	80322105 
$20 < G \leq 24$	80322106 	80322106 
$24 < G \leq 28$	80322107 	80322107 
$28 < G \leq 32$	80322108 	80322108 
$32 < G \leq 34$	80322109 	80322103 
$34 < G \leq 36$	80322109 	80322104 
$36 < G \leq 38$	80322109 	80322105 
$38 < G \leq 40$	80322109 	80322106 
$40 < G \leq 42$	80322109 	80322107 
$42 < G \leq 45$	80322109 	80322108 
$47 \leq G \leq 49$	80322109 	80322128 

Fig. 41 Selection of glass-fixing angles in the leaf frame or top/sidelight frame (standard variant with 120540 – 120542 seals)

MB -78EI Fire-rated doors and technical windows installation guide











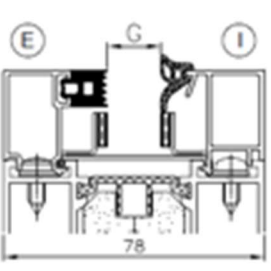
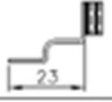
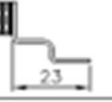
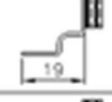







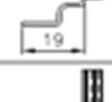

	Glazing angles – full set	
	E	I
16	80322104 	80322104 
$16 < G \leq 19$	80322106 	80322104 
$19 < G \leq 22$	80322106 	80322106 
$22 < G \leq 25$	80322106 	80322107 
$25 < G \leq 28$	80322107 	80322107 
$28 < G \leq 31$	80322106 	80322128 
$31 < G \leq 33$	80322107 	80322128 
$33 < G \leq 37$	80322160 	80322107 
$37 < G \leq 40$	80322159 	80322107 
$40 < G \leq 43$	80322160 	80322128 
$43 < G \leq 46$	80322159 	80322128 
$46 < G < 49$	80322109 	80322128 

Fig. 42 Selection of glass-fixing angles in the leaf frame or top/sidelight frame (special variant for glazing external constructions on upper floors, which eliminates the need to use scaffoldings)

MB -78EI Fire-rated doors and technical windows installation guide





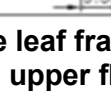
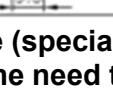

	Glazing angles – full set		E – external side I – internal side
	E	I	
$49 \leq G \leq 52$	80322160 	80322161 	
$52 < G \leq 55$	80322159 		
$55 < G \leq 59$	80322109 		
	Glazing angles – full set		E – external side I – internal side
	E	I	
$61 \leq G \leq 65$	80322124 	80322161 	

Fig. 43 Selection of glass-fixing angles for glass thicker than 49mm in the leaf frame or top/sidelight frame (special variant for glazing external constructions on upper floors, which eliminates the need to use scaffoldings)

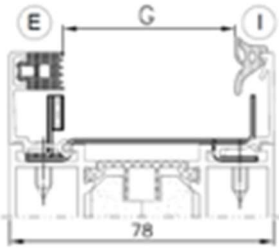
MB -78EI Fire-rated doors and technical windows installation guide

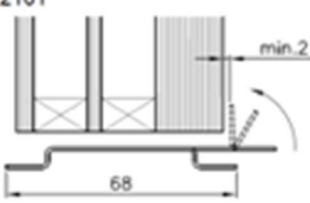
	E			I			E – external side I – internal side	
	120542	120541	120540	120540	120541	120542		
							E	I
16	●					●	K430300X	K430300X
16 < G ≤ 19		●				●		
19 < G ≤ 22			●	●				
22 < G ≤ 25	●					●	K430301X	K430301X
25 < G ≤ 28		●				●		
28 < G ≤ 31			●	●				
31 < G ≤ 32	●					●	K430302X	K430302X
32 < G ≤ 34		●		●			K430303X	K430304X
34 < G ≤ 36		●				●	K430303X	K430300X
36 < G ≤ 38		●				●		
38 < G ≤ 40		●				●	K430303X	K430301X
40 < G ≤ 42		●				●		
42 < G ≤ 44		●		●				
44 < G ≤ 45			●	●				
47 ≤ G ≤ 49		●		●			K430303X	K430302X

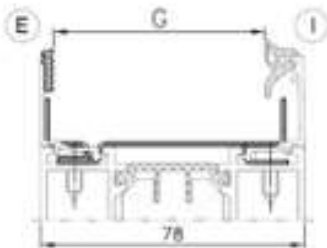
Fig. 44 Selection of gaskets and glazing beads in the leaf/panel frame (standard variant)

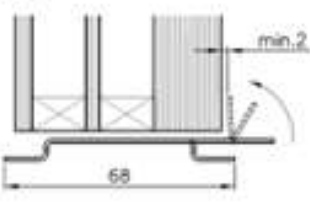
E – external side I – internal side	E		I	
	K430328X	K430301X	120540 120541 120542	120451 120449
26 ≤ G < 27				
27 ≤ G < 28				
28 ≤ G < 29				
29 ≤ G < 30				
30 ≤ G < 31				
31 ≤ G < 32				
32 ≤ G < 33				
33 ≤ G < 34				
34 ≤ G < 35				
35 ≤ G < 36				
36 ≤ G < 37				
37 ≤ G < 38				
38 ≤ G < 39				
39 ≤ G < 40				
40 ≤ G < 41				

Fig. 45b Selection of gaskets and glazing beads fixing the pane in the leaf/wall frame (special variant for glazing outdoor constructions on upper floors, which eliminates the need to use scaffoldings)

7.3. "Push-out" of the door leaf

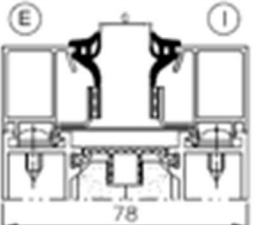
The correct push-out of the leaf is a very important step during installation because the glass, through the installed blocks, causes stiffening of the construction, and the push-out procedure ensures the correct, rectangular shape and proper operation of the door leaves.

Hardwood blocks, preferably beech, up to 5 mm thick, should be used to push out the door leaf. Fixing is made as shown in Fig. 46 and you should pay attention to the location of the blocks – in the leaves, the blocks are always placed on the hinge side in the lower corner and in the upper corner on the handle side, in the gap between the glass and the leaf profile.

If the leaf is horizontally divided, the same procedure applies to each glass pane. The blocks must be protected against sliding with fireproof silicone, catalogue no. 14614967.

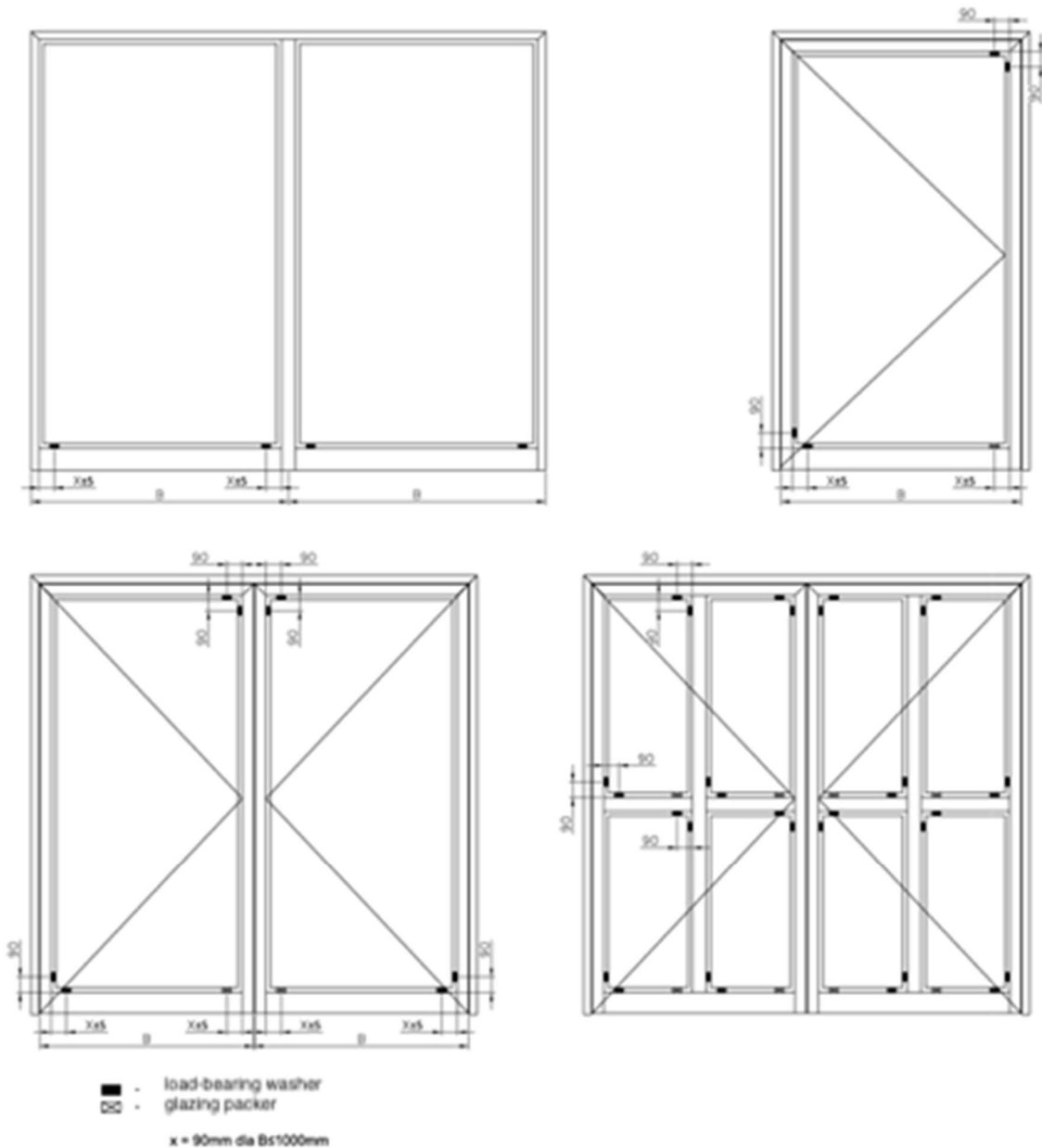

Fig. 46 'Push-out' of glazing in door leaf/frames. Rules for placement of glazing packers, $x = 90\text{mm}$ for $B \leq 1000\text{mm}$

8. Final check of the correctness of installation

The installation check shall include:

- correctness of frame embedding: parallelism, squareness of construction elements,
- correctness of door or wall fixing, including correctness of filling gaps between the frame and the building aperture
- correct operation of the lock (latch and bolt),
- correct operation of door fittings (door closer, drop down seal, access control, emergency exit devices),
- correctness of glass embedding,
- correctness of the self-closing of the door,
- verification of the minimum force required to open the door,
- door marking in accordance with the rules of product marking with the B mark or CE mark

9. Care and maintenance for glazed aluminium constructions

9.1. Care and maintenance for exterior wall glass

Glass is inherently hard, resistant and easy to clean. Observing the following recommendations will help to maintain its cleanliness, transparency and brilliance for many years to come.

9.1.1. Cleaning of glass on site after installation

During the first cleaning after installation, the glass may be heavily soiled. The following cleaning steps are recommended:

- products containing hydrofluoric acid or fluorine derivatives must not be used for cleaning as they may damage the coating and surface of glass, the same applies to products with strong acid or strong alkaline reaction and abrasive products (pay attention to the compatibility of the products used with other components of the glazed aluminium construction, such as protective coatings on aluminium, gasket material, sealing agents, etc.),
- stickers and cork spacers should be removed as soon as possible
- traces of cement sludge and other building materials should be removed from glass immediately – if left for too long, they may cause permanent damage to the glass (loss of gloss),
- do not dry-remove cement dust or other abrasive residues,
- rinse the panes thoroughly with clean water in order to remove as much dust as possible, remove excess water with a rubber wiper
- carefully inspect the glass and remove any remaining dirt and carefully remove any remaining sealants, mastic, mortar, etc. using a special scraper or razor blade (due to a

MB -78EI Fire-rated doors and technical windows installation guide

high risk of scratching the glass, special care should be taken, especially when cleaning different types of coated glass),

- carry out another cleaning operation with clean water or water with addition of a neutral cleaning agent or any other available product for cleaning glass
- the cleaning water and cloths or sponges must be free of sand and other foreign matter.

9.1.2. Routine and periodic glass maintenance

9.1.2.1. Cleaning frequency

The frequency of cleaning depends on the ambient conditions and the degree of environmental pollution. Glass gets dirty more quickly in dusty industrial areas, traffic-intensive districts, coastal areas and places where glass panes are rarely exposed to rain. Glass must be cleaned so that standard cleaning would be sufficient to keep the glass clean. The minimum recommended frequency is six months.

9.1.2.2. Standard cleaning

In most cases it is enough to clean the glass with plenty of clean water. Every now and then, you can add a small amount of neutral cleaner or other commercially available glass cleaning product to the water. Use rubber windscreen wipers or special wipers. After cleaning, rinse the glass thoroughly with clean water and collect excess liquid with a rubber wiper.

Do not clean glass when it is exposed to the full sun. You should also avoid cleaning the glass when the temperature is very low or very high.

9.1.2.3. Special cleaning

If standard cleaning is ineffective, other methods can be used: grease stains and other organic contaminants should be removed with solvents such as isopropyl alcohol or acetone, applied to dirty surfaces with a soft, clean cloth. Other impurities should be removed by slightly polishing the surface with an aqueous suspension of cerium oxide (diluted 100 to 200 grams of powder per litre of water), then rinsing the surface with water, and then following the recommendations for standard cleaning.

9.1.2.4. Special conditions for the protection and maintenance of glass

Renovations and modernizations are carried out throughout the operational life of a building. The following recommendations must be adhered to:

MB -78EI Fire-rated doors and technical windows installation guide

- avoid soiling of glass surfaces with plaster or concrete residues, rust, excessive amount of dust,
- the glass must be protected so that metal droplets from welding work and swarf from cutting metal parts do not come into contact with glass, as they can cause irreversible damage to the glass surface (if necessary, glass surfaces must be covered with tarpaulin or plastic cloth or cardboard),
- protect glass surfaces from soiling with façade paints, façade treatment products, interior wall paints, etc.

9.2. Maintenance of coatings on aluminium profiles

The effect of coated and anodized coatings will be maintained as long as maintenance work is carried out frequently and correctly. The durability of coatings on aluminium construction elements is significantly influenced by climatic and atmospheric conditions at the place of installation, the effects of aluminium connections with other metals or some building materials, the frequency of maintenance, and the way the maintenance is carried out.

9.2.1 Cleaning of aluminium constructions after installation

After completing the installation of the construction, embedding the glass and adjusting the mechanisms, proceed to washing and cleaning operations. The most important operations include:

- immediate removal of the protective film, because, when exposed to the sun and high temperature, this can lead to chemical reactions which can result in the tape being fused with the powder coating or other damage and discolouration,
- if, due to the ongoing construction process, it is necessary to leave a protective film, and the construction is not directly exposed to UV rays and high temperatures, the film may be removed no later than 3 months from its placement – the installer is obliged to inform the user/client about it by drawing up a report,
- if the carrier of the protective tape remains on the surface of the product, it should be removed by cleaning it with a soft cloth with mineral spirit, in case of difficulties with the removal, the manufacturer of the glazed aluminium construction should be notified,
- aluminium profiles with anodized or painted oxide coatings should be cleaned with a soft cloth using clean water or water with addition of mild detergents, the temperature of washing liquids and the surface of the cleaned elements must not exceed 25⁰ C (hot water, jet of steam must not be used),
- the surfaces of the profiles should be dried by wiping with delicate cotton fabrics; during this procedure, the fabric should not be pressed too hard against the cleaned surface,
- additional information related to surface cleaning are given in sections 9.2.2 – 9.2.4.

9.2.2. Frequency of coating maintenance and cleaning

MB -78EI Fire-rated doors and technical windows installation guide

Elements of aluminium constructions should be maintained at a frequency resulting from the place of operation, and in particular from the corrosive aggressiveness of the natural environment:

- in slightly aggressive environments (rural, small towns) - at least 2 times a year,
- in moderately aggressive environments (small towns, high traffic routes, medium-sized towns with low industrialization) - at least 3 times a year,
- in highly aggressive environments (highly industrialised cities with very high traffic) - minimum 4 times a year.

9.2.3. Routine and periodic maintenance of coatings in glazed aluminium constructions

- it is recommended to check each time on invisible surfaces of the construction whether the applied cleaning agent or water solution of the cleaning agent (with the exception of clean water) does not react with the coating,
- anodized or powder-coated aluminium profiles should be cleaned with a soft cloth using mild cleaning agents, do not use liquids based on highly alkaline or acidic compounds, which may cause damage to oxide or powder coatings,
- do not use cleaning agents with a pH below 5 and above 8; the surface temperature of the construction and the water temperature must not exceed 25°C,
- after each cleaning, the surface must be immediately rinsed with clean cold water,
- while cleaning, do not use abrasive cleaners and do not clean the surface by friction,
- it is allowed to use soft cotton cloth intended for industrial cleaning, and, while wiping, do not force too much the cloth to the cleaned surface,
- do not use organic solvents containing esters, ketones, alcohols, aromatics, glycol esters, chlorinated hydrocarbons, and the like; do not use detergents of unknown origin.

9.2.4. Special conditions for the protection and maintenance of coatings in glazed aluminium constructions

Renovations and modernizations are carried out throughout the operational life of a building. The following recommendations must be adhered to:

- avoid soiling of coatings with plaster or concrete residues, excessive amount of dust,
- protect construction surfaces from soiling with façade paints, façade treatment products, interior wall paints, etc.,
- powder coatings are sensitive, i.a. to organic solvents, concentrated alcohol, acids, bases, and petroleum-derived compounds; it is imperative to avoid contact with the above-mentioned substances,
- in particular, coatings must be protected against contact with lime, cement and other alkaline building materials by sticking a protective film on the profiles for the time of the renovation or by covering the entire structure with film,

MB -78EI Fire-rated doors and technical windows installation guide

- profile surface must be protected so that metal droplets from welding work and swarf from cutting metal parts do not come into contact with coating, as they can cause irreversible damage to the coating (if necessary, profile surfaces must be covered with tarpaulin or plastic cloth or cardboard).

9.3. Maintenance of doors and fittings

9.3.1. Frequency of door inspections and maintenance of fittings and mechanisms

Maintenance and inspection services for the functionality and smooth operation of doors should be carried out by their manufacturer or an authorized service technician:

- at least once every six months for fire doors - the building owner is responsible for the implementation of the programme and the inspection frequency,
- at the frequency recommended by the manufacturers of fittings and mechanisms, but not less often than once every six months
- once a month for fire doors on exit paths fitted with panic or emergency opening mechanisms.

9.3.2. Standard maintenance

During the maintenance:

- clean the doors and fittings from all possible impurities to prevent blockage or seizure of door equipment mechanisms, use mild cleaning agents recommended for the maintenance of coatings and, for lubricated or oiled elements, use extraction gasoline for cleaning,
- check the condition of protective coatings on the frame and leaf profiles and carry out maintenance in accordance with the description given in sections 9.2.2 – 9.2.4,
- check the correct operation of all door components, and, above all:
 - a) check the dimension and correctness of the leaf geometry and check the dimensions and uniformity of the clearance between the leaf and the frame, and between the active leaf and the inactive leaf; if non-conformity with the installation documentation, adjust the hinges,
 - b) check that the hinges, handles, door closers and all other fittings are securely fastened, tighten the fixing screws if necessary (the tightening torque should be in accordance with the fittings manufacturers' guidelines),
 - c) check the smoothness of closing and opening of door leaves, especially doors fitted with door closers, by opening the door leaf with at least 30° for door closers without sequence selector,
 - d) verify that no devices have been added to the door or that any devices have been removed, as this may affect its operation,
 - in case of detecting the presence of additional fittings or mechanisms, these should be removed or the door should be disused, and the owner/facility manager should be notified of that fact,
 - in the case of unauthorized dismantling of fittings or mechanisms these should be supplemented with the same type as in the design, or the door should be disused until

MB -78EI Fire-rated doors and technical windows installation guide

it is fully supplemented with fittings or mechanisms. The owner/facility manager should be notified of that fact,

- check the fastening security and condition of all seals and gaskets,
- inspect the lock by checking the smoothness of operation, check the condition of the lock latch, oil the lock at least once a year,
- check the smooth operation of the lock cylinder, in case of malfunctions, replace the lock cylinder with a new one of the same type and from the same manufacturer,
- hinges used in glazed aluminium constructions should not be lubricated,
- carefully inspect the door closer, including;
 - a) check that the door closer components are securely fastened to the frame and leaf, remove the leaf clearance by tightening,
 - b) oil all parts of the arm,

 - c) check door closer adjustments: compression force and closing speed and check the smooth running of the door leaf,
 - d) check that the speed of the door closer is adjusted within the limits specified by the manufacturer,
 - e) for door closers with additional functions, follow the manufacturer's recommendations,
 - f) damaged door closers must be replaced immediately with new ones.

9.3.3. Service and maintenance of emergency exit doors

Care and maintenance should be carried out once a month. In addition to standard maintenance described in section 9.3.2. the maintenance shall include:

- control of the operation of the panic device by activating it and measuring the force necessary to release the device,
- check the cleanliness of the keepers and the smooth operation of the bar elements as well as the degree of lubrication, if negative, lubricate the mechanisms,
- periodic check of the correctness of the bar tension together with the measurement of the operating force of the release of the panic device.

Note: In case of damage to the fittings, it is imperative to contact door/fittings manufacturer in order to choose, order-pick and replace the damaged product.

10. Operation of doors and door components

In order to open a door fitted with standard fire door devices, press the handle and, simultaneously, pull the leaf or push it, depending on the direction of opening. To close the door, push the leaf or pull the handle, left in a horizontal position. Opening and closing the leaf must always be done with the handle in order to avoid the risk of trapping fingers between the frame and the leaf.

10.1. Operation of primary door locks

MB -78EI Fire-rated doors and technical windows installation guide

1. Lock locked with a handle

If the leaf is in the closed position in order to permanently close the door, lift the handle upwards to hear a click, which indicates that the bolt is locked and then perform 1 turn with the key to close the bolt. To open the leaf, unlock the bolt, turn the key in the opposite direction and press the handle.

2. Lock locked with lock cylinder

When the door leaf is in the closed position, in order to permanently close the door, perform 2 full turns with a key to close the bolt. To open the door, make 2 full turns in the opposite direction and press the handle.

3. Automatic multipoint lock

This type of locks has a magnetic locking system, which allows for automatic locking of doors without user's intervention. When the leaf reaches the frame, the locking mechanism starts automatically and in order to eject the main bolt, 1 turn of the key is required. To unlock the door, make 1 full turn in the opposite direction and press the handle.

10.2. Door operation

10.2.1. Opening and closing of single doors

A. Opening and closing the door from the outside

Opening:

- insert the key into the cylinder and turn it as far as it will go and hold it briefly while slightly tilting the door,
- push or pull the door while holding the handle.

Closing:

- close the door,
- turn the key in the lock.

B. Opening and closing the door from the inside

Opening:

- press the handle or push pad,
- depending on the opening direction, push or pull the door while holding the handle.

Closing:

- close the door,
- turn the key in the lock.

10.2.2. Opening and closing the door with electric deadbolt

A closed door can be unlocked by pressing a button -- as long as the button is pressed.

It is possible to permanently unlock the latch allowing the door to be opened at any time (the so-called "daily option" of using the door). The latch is unlocked by moving the locking lever _____

MB -78EI Fire-rated doors and technical windows installation guide

downwards and the latch is locked by moving it upwards. The “day option” only works if the door is not key-locked.

10.2.3. Opening and closing of double doors

In order to open a double door, the active leaf must first be opened in the manner described in section 8.2.1, then open the inactive leaf by raising the locking levers located in the upper and lower parts of the leaf.

10.2.4. Opening and closing of double emergency exit and panic doors

The following are the basic steps of operating the door to enable exit from buildings and rooms in the event of failure or panic. Both emergency exit or panic door mechanisms must allow exit from the room or building at all times. These mechanisms allow the door to be used in normal and hazardous conditions. In case of entering the building through such a door, access from the outside can be done mechanically (key) or electrically (remote control, button). Exiting from the inside is done by mechanically releasing the device without any delay.

10.2.4.1. Opening and locking of emergency exit doors using handles and/or push pads

1. Opening and closing the active leaf from the outside

- insert the key into the cylinder and turn it 2 times as far as it will go and hold it briefly while slightly tilting the door,
- pull the door while holding the handle or knob,
- close in reverse order.

2. Opening the inactive leaf from the outside

- open the active leaf as described in section 1,
- press down the handle (or push pad) on the inside,
- close in reverse order.

3. Opening and closing the active leaf from the inside

- press the handle or push pad and push the leaf,
- the leaf will also open when the bolt is locked.

4. Opening the inactive leaf from the inside

Due to a wide range of emergency door devices, the use of doors in facilities where the probability of panic is low and the user is familiar with the function of the door and the operation of the mechanisms, various configurations of devices in double doors are possible.

e.g. Variant 1.

- open the active leaf as described in section 3,
- the leaf will also open when the bolt is locked,

MB -78EI Fire-rated doors and technical windows installation guide

- press the handle or push pad attached to the inactive leaf,
- close in reverse order.

e.g. Variant 2.

- press the handle or push pad attached to the inactive leaf,
- active and inactive leaves open even if the door lock is locked.

10.2.4.2. Opening and locking of emergency exit doors using panic devices

Panic doors can be opened at any time in case of danger by pressing the horizontal exit bar on the door leaves in the direction of the horizontal exit. The advantage of the solution is that the users do not need to get acquainted with the principle of these mechanisms and their operation.

1. Opening and closing the active leaf from the outside

- unlock the active leaf by turning the key anticlockwise,
- press the handle to open the leaf by pulling it towards yourself,
- close in reverse order.

2. Opening and closing the active and inactive leaf from the inside

2.1. Opening the active leaf from the inside

- press the panic bar mounted on the active leaf, the active leaf opens even if the door lock is locked.

2.2. Opening the inactive leaf from the inside

- press the panic bar mounted on the inactive leaf, the active and inactive leaves open even if the door lock is locked.

10.3. Using doors fitted with door closer

The door closer is a device which automatically moves the door leaf from the open position to the closed position. To close the door, pull the handle or holder once in the direction in which the door closes, and the door closes automatically.



T: +44 (0) 116 2289 3343 E: info@facadecreations.co.uk W: www.facadecreations.co.uk
Registered in England, Company Number: 16267073