



FAÇADE CREATIONS

Friction Arms Guide

Façade Creations Friction Arms

FA102/HD102

For windows supported by standard butt hinges, (and in some cases friction stays) the Façade Creations friction arm offers distinct advantages over the conventional peg stay. It is totally concealed when the vent is closed and offers no internal obstruction when opened.

- For large top hung vents the friction arm can be used as an extra support by fitting it below the existing friction stay. This has the effect of limiting the opening as well as adding greater stability to the window.
- Can be used to limit the window opening to a maximum of 90°
- Independently tested by BRE global.
- Tested to comply to CEN13126-5:2004.
- Available in 6", 10" and 14" in standard duty (FA102) and 10" in heavy duty (HD102).



Façade Creations Friction arms - Sizes & Measurements

Sizes Available	'A' REF	'B' REF	'C' REF	'D' REF
FA-6"	79.25	133.35	57.2	152.6
FA-10"	180.1	236.0	57.2	245.0
FA-14"	266.95	399.95	57.2	355.81
HD-10"	214	242	56.0	260

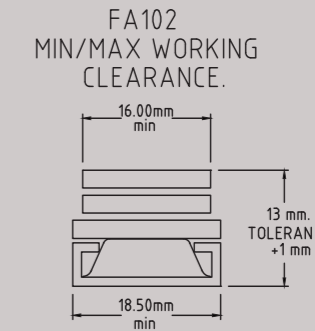
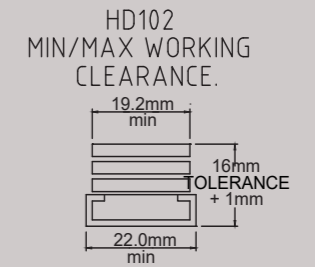
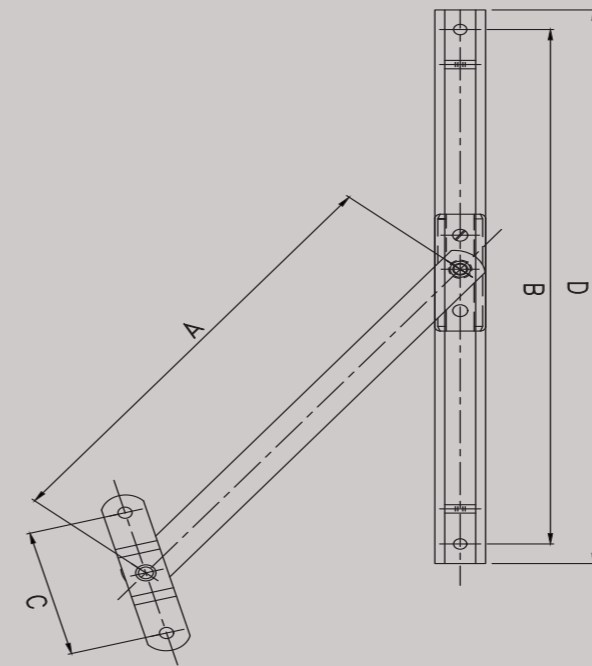

Optimum Performance Tested to last

- BBA certified.
- FA102 is manufactured using 430 Grade Ferritic Stainless Steel
- HD102 is manufactured using high grade Austenitic Stainless Steel.
- Independently tested by BRE global.
- Tested to comply to CEN13126-5:2004.

Note: For larger or heavier sashes, all sash fixings should pick up reinforcement to ensure consistent performance.



It is the responsibility of the window manufacturer to ensure that the finished window meets the required safety and performance specifications.



T: +44 (0) 116 2289 3343 E: info@facadecreations.co.uk W: www.facadecreations.co.uk
Registered in England, Company Number: 16267073